

Technical manual

Butterfly valves Sylax FM - CNPP

CNPP Version (National Center for Prevention and Protection) : DN32/40 - DN300 mm

FM Version (Factory Mutual approval) : DN32/40 - DN300 mm



Summary



• Sale leaflet	p.2
• Spare parts list	p.4
• Overall dimensions	p.6
• Extension shaft	p.8
• Electric wiring	p.9
• Connecting flanges	p.10
• Normalisation	p.11
• Pressure/Temperature	p.12
• Torque value	p.12
• Flow rate (Kv)	p.13
• Head loss diagram (Δp)	p.14
• Type of flange	p.15
• Tag/Traceability	p.15
• Bolts and nuts	p.16
• Installation	p.18

Applications and main characteristics

Sprinkler systems

Applications :

- Sprinkler systems
- For special applications such as lug type body, alu-bronze or stainless steel disc ..., contact our technical back office team.

Main characteristics :

- Butterfly valves with gear box, dedicated to sprinkler systems, equipped with chain and padlocks (CNPP version only).
- CNPP approval n° YO/AL/12/037 dated 02/12/2003
- Factory Mutual approval n° 3029234 (Sylax FM)
- Competitive quality and price ratio
- Reliability

An instruction notice specifying the installation characteristics and the commission of the Sylax FM-CNPP is available on our web site www.socla.com or on request by our sales department.

Sale leaflet

By concentrating the technologies and by integrating technical solutions of the highest levels, **Socla** fulfils its ambition :

- competitiveness of a standard range,
- reliability,
- comprehensive range thanks to a multiplicity of solutions.

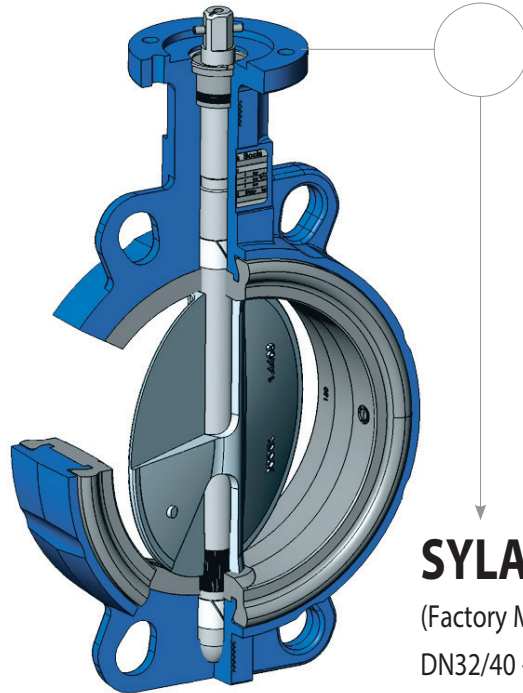

SYLAX FM VERSION

(Factory Mutual approval)

DN32/40 - DN300 mm

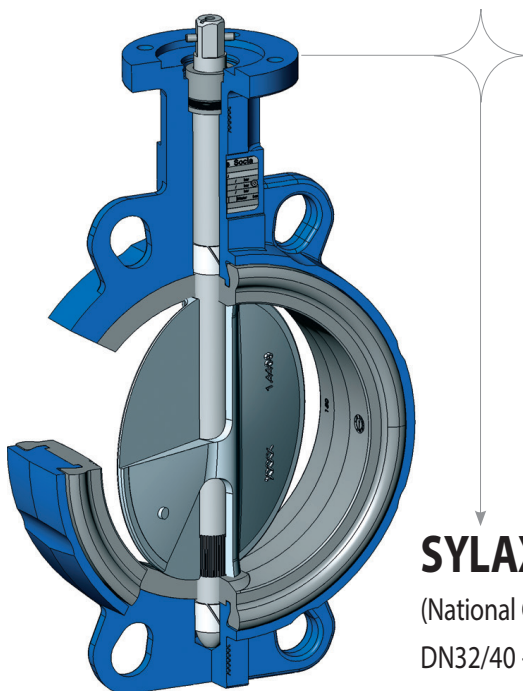

SYLAX CNPP VERSION

(National Center for Prevention and Protection approval)

DN32/40 - DN300 mm

Sale leaflet

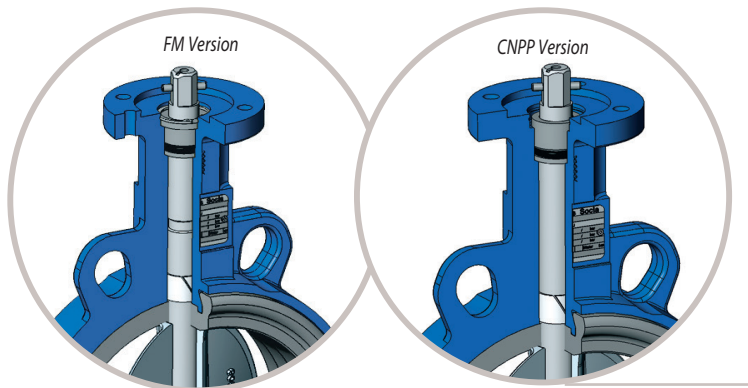

- Safety anti-ejection circlip keeps shaft in place and allows easy maintenance (FM version only)
- Safety reinforced by a secondary water tightness
- Spline driven one piece shaft connected to floating disc :

. high reliability of tightness and torque transmission in the long term.

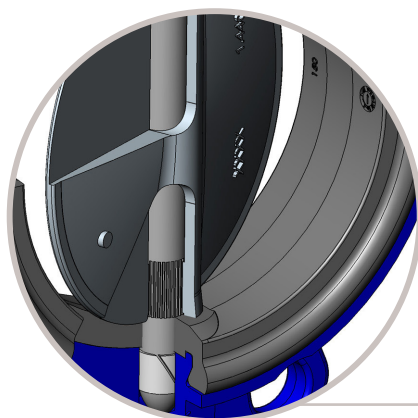

- High power transmission with robust grooved connection between the shaft and the disc.
- Complete protection of the shaft and valve body from fluids.
- Reliability of movements with self-lubricating bearings.



- Identification and traceability ensured by riveted metal tag : see on page 15.

Spare parts list

CNPP Version - DN32/40 - DN300 mm

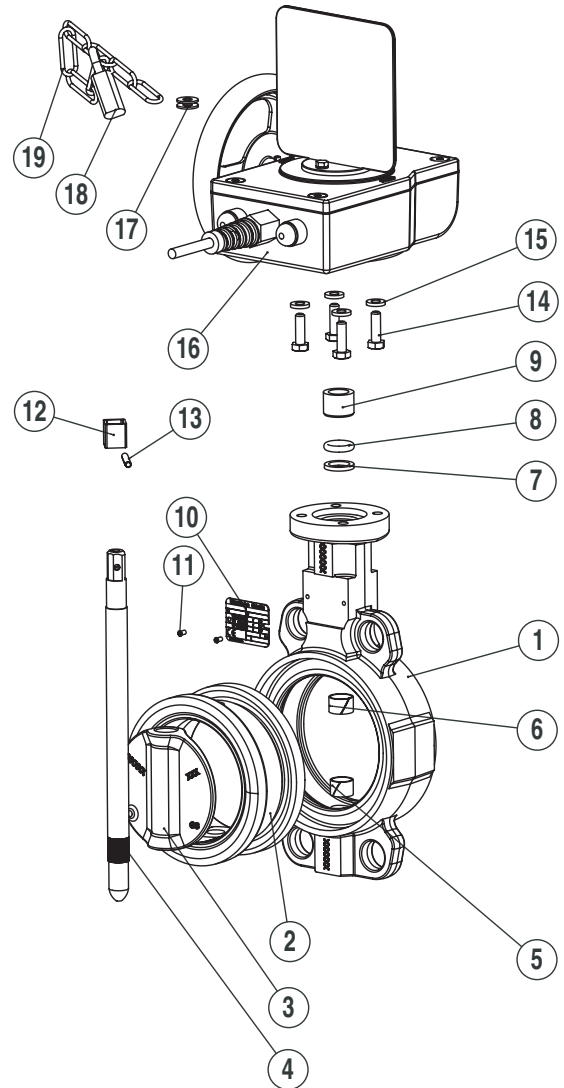
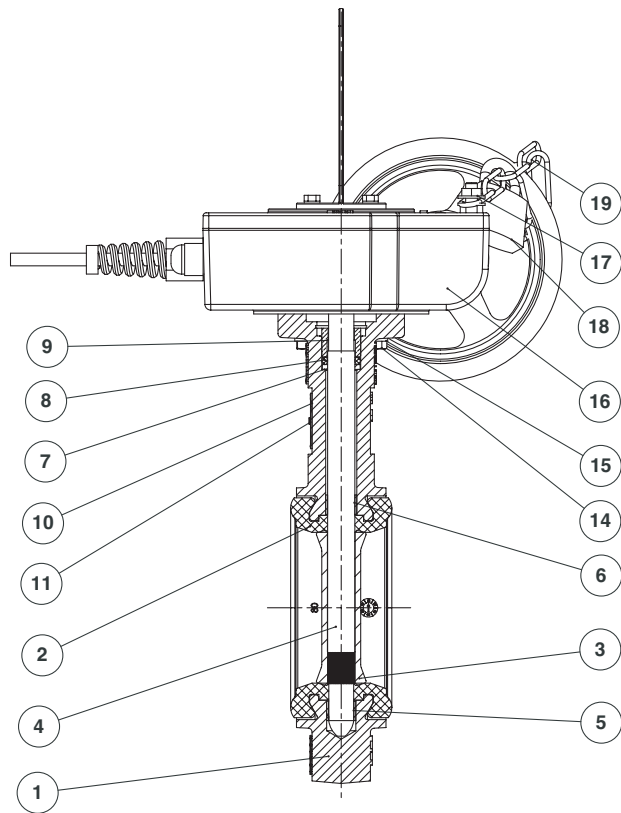

Nb.	DESCRIPTION	Qty	MATERIALS ACCORDING TO NORMS			
			Materials	EN	ASTM	JIS
1	Body	1	Ductile iron	EN GJS 400-15 (JS1030)	-	FCD40
2	Liner	1	EPDM	-	-	-
3	Disc	1	Ductile iron	EN GJS 400-15 (JS1030)	-	FCD40
			Stainless steel	GX5 CrNiMo 19-11-2 (1.4408)	316	SUS 316
			Stainless steel	GX2 CrNiMo 19-11-2 (1.4409)	316L	SUS 316L
4	Shaft	1	Cupro - Aluminium	CuAl10Fe5Ni5 (C333G)	-	-
			Stainless steel	X5 CrNiCuNb 16-4 (1.4542)	630	SUS 630
			Stainless steel	X2 CrNiMo 17-12-2 (1.4404)	316L	SUS 316L
			Stainless steel	X30 Cr13 (1.4028)	420	SUS 420 J2
5	Anti-friction bearing	1	Zinc coated steel/PTFE	-	-	-
6	Anti-friction bearing	1	Zinc coated steel/PTFE	-	-	-
7	Anti-extrusion bush	1	Plastic	IXEF 50 FV	-	-
8	O-ring	1	Nitrile	-	-	-
9	Sealing washer	1	Brass	CuZn39Pb2 (CW612N)	-	-
10	Identification plate	1	Aluminium	EN AW - AL995 (EN AW - 1050A)	-	-
11	Rivet	2	Alu/Stainless steel	-	-	-
12	Counter square (1)	1	Steel	-	-	-
13	Pin	1	Steel	-	-	-
14	Screw H	4	Zinc coated steel	-	-	-
15	Elastic washer	4	Zinc coated steel	-	-	-
16	Gear box CNPP approved	1	Aluminium	-	-	-
17	Flat washer	2	Zinc coated steel	-	-	-
18	Padlock	1	Steel + brass	-	-	-
19	Chain	1	Steel	-	-	-

(1) DN32/40 to 100 and DN250

Spare parts list

FM Version - DN32/40 - DN300 mm

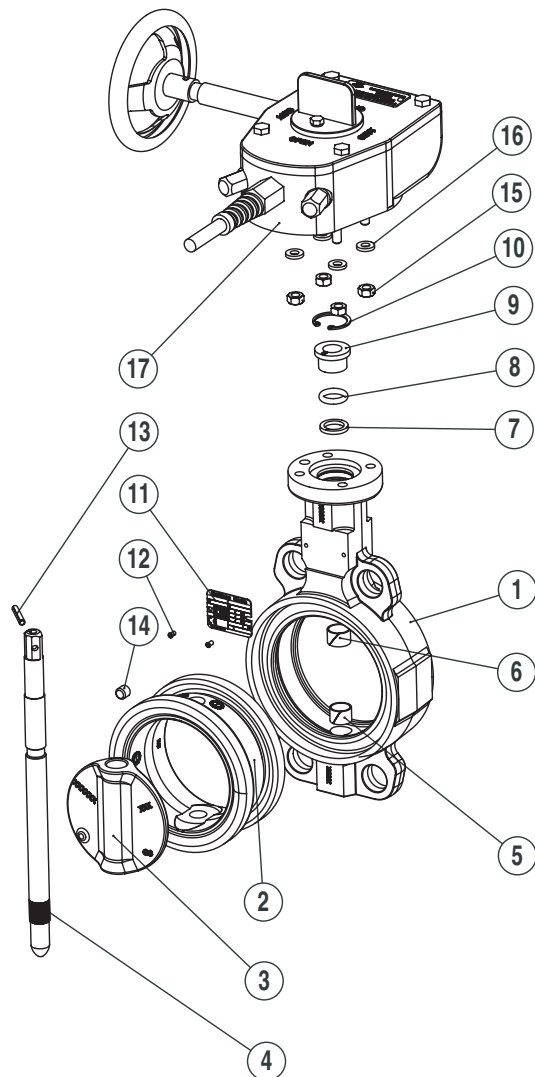
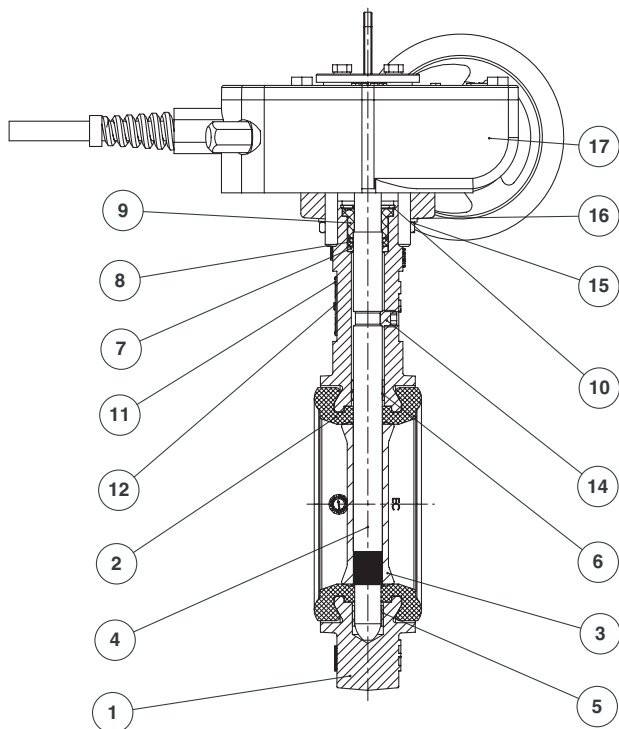

Nr	DESCRIPTION	Qty	MATERIALS ACCORDING TO NORMS			
			Materials	EN	ASTM	JIS
1	Body	1	Ductile iron	EN GJS 400-15 (JS1030)	-	FCD40
2	Liner	1	EPDM	-	-	-
3	Disc	1	Ductile iron	EN GJS 400-15 (JS1030)	-	FCD40
			Stainless steel	GX5 CrNiMo 19-11-2 (1.4408)	316	SUS 316
			Stainless steel	GX2 CrNiMo 19-11-2 (1.4409)	316L	SUS 316L
			Cupro-aluminium	CuAl10Fe5Ni5 (C333G)	-	-
4	Shaft	1	Stainless steel	X30 Cr13 (1.4028)	420	SUS 420 J2
5	Anti-friction bearing	1	Zinc coated steel + PTFE	-	-	-
6	Anti-friction bearing	1	Zinc coated steel + PTFE	-	-	-
7	Anti-extrusion bush	1	Plastic	IXEF 50 FV	-	-
8	O-ring	1	Nitrile	-	-	-
9	Sealing washer	1	Plastic	IXEF 50 FV	-	-
10	Circlips	1	Steel	XC 75	-	-
11	Identification plate	1	Aluminium	EN AW - AL995 (EN AW - 1050A)	-	-
12	Rivet	1	Alu/Stainless steel	-	-	-
13	Pin	1	Steel	-	-	-
11	Identification plate	1	Aluminium	-	-	-
14	Headless screw	1	Zinc coated steel	-	-	-
15	Nut	4	Zinc coated steel	-	-	-
16	Elastic washer	4	Zinc coated steel	-	-	-
17	Gear box FM approved	1	Ductile iron	-	-	-

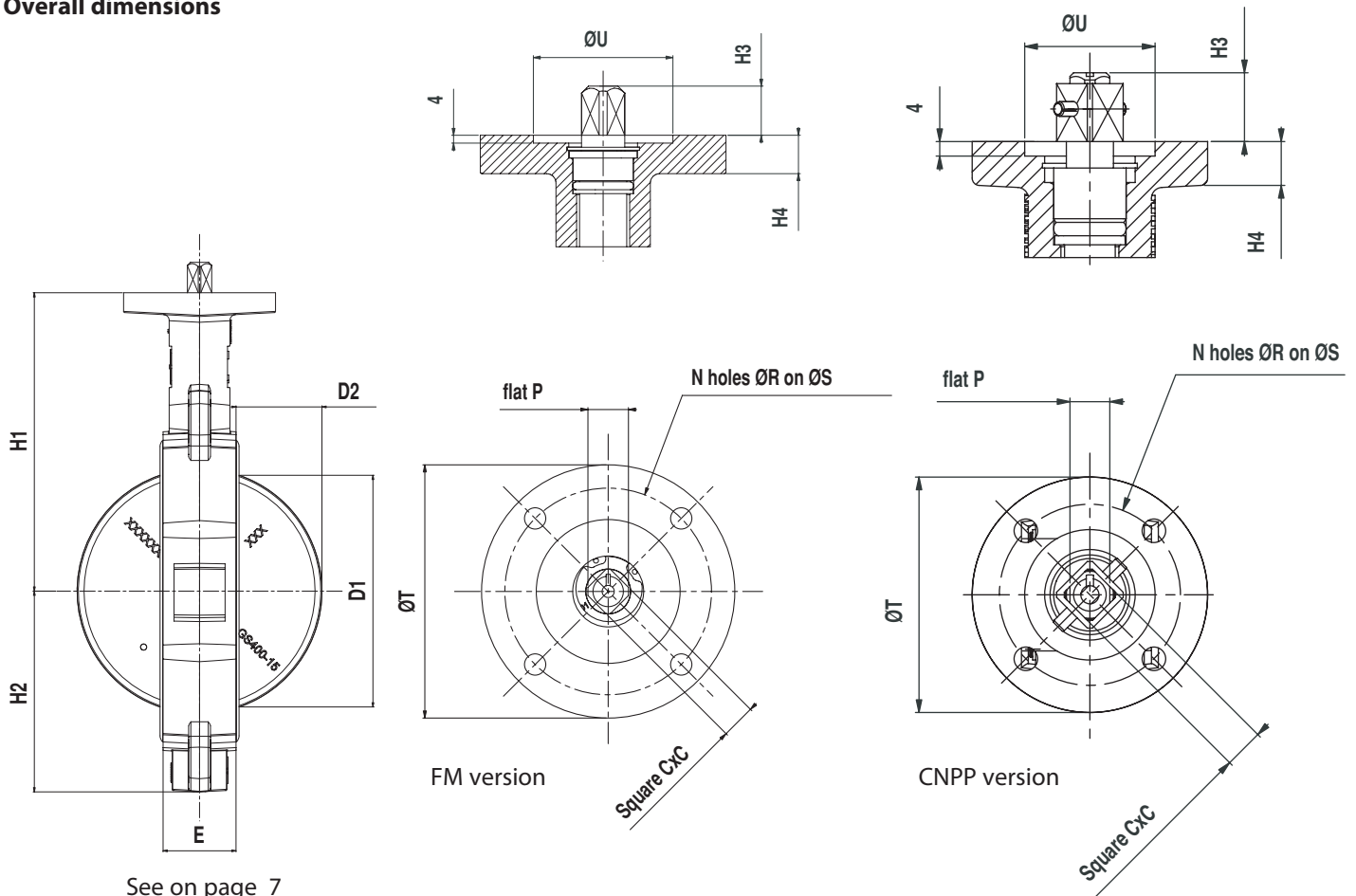
Overall dimensions

DN	NPS	Iso top according to ISO 5211						Square drive outlet			
		N	ØR	ØS	ØT	ØU	N°	oC	H3	flat P	H4
32/40	1 ^{1/2}	4	6,5	50	65	36	F05	11*	19	11	12
50	2	4	6,5	50	65	36	F05	11*	19	11	12
65	2 ^{1/2}	4	6,5	50	65	36	F05	11*	19	11	12
80	3	4	6,5	50	65	36	F05	11*	19	11	12
100 FM	4	4	8,5	70	90	56	F07	14	19	14	12
100 CNPP	4	4	6,5	50	65	36	F05	11*	19	11	12
125	5	4	8,5	70	90	56	F07	14	19	14	12
150	6	4	8,5	70	90	56	F07	14	19	14	12
200 FM	8	4	10,5	102	125	71	F10	17	25	20	15,5
250 FM	10	4	10,5	102	125	71	F10	22	32	26	16
300 FM	12	4	12,5	125	150	87	F12	22	29	26	16
200 CNPP	8	4	8,5	70	90	56	F07	14	19	14	12
250 CNPP	10	4	10,5	102	125	71	F10	17**	24	20	14
300 CNPP	12	4	10,5	102	125	71	F10	22	29	22	14

* with conversion sleeve 14x11

** with conversion sleeve 17x22

Overall dimensions

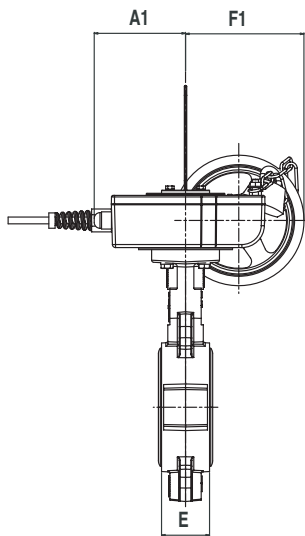

CNPP version

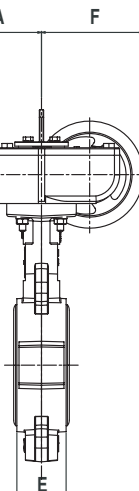
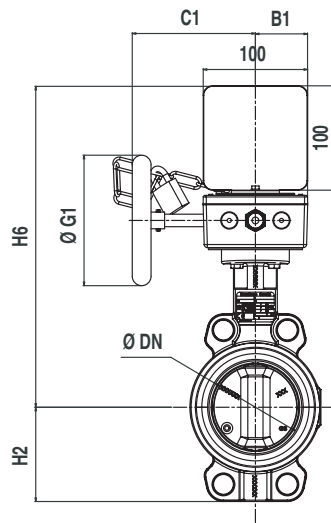

FM version

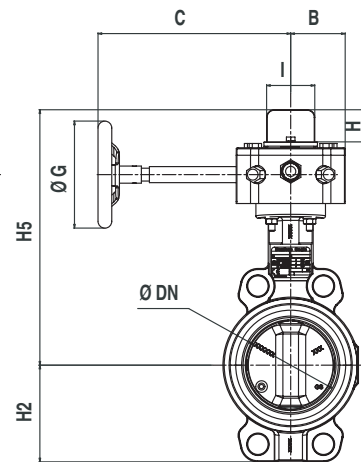

Centring lugs

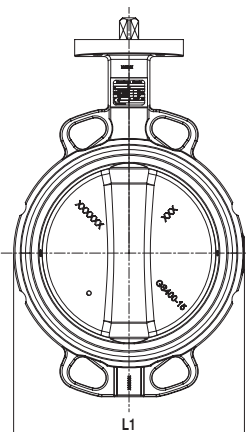

Diameter	Face to face	Overall dimensions						Iso top according to ISO 5211											Travel of the disc		Weight (kg)		
		DN	NPS	E	L1	H1	H2	H5	H6	A	A1	B	B1	C	C1	F	F1	G	G1	H	I	D1	D2
32/40	1 1/2	32	144	130	57	232	287	74	84,5	40	50	168	118	93	110,5	100	125	50	55	31	6,5	4,7	3,2
50	2	43	121	136	62	238	294	74	84,5	40	50	168	118	93	110,5	100	125	50	55	29	4,5	5,1	4,5
65	2 1/2	46	136	145	83	247	303	74	84,5	40	50	168	118	93	110,5	100	125	50	55	48	10	5,5	4,7
80	3	46	127	151	89	253	309	74	84,5	40	50	168	118	93	110,5	100	125	50	55	67	18	5,8	4,8
100	4	52	153	175	106	277	333	74	84,5	40	50	175	118	105,5	110,5	125	125	50	55	88	25	7,7	7
125	5	56	182	190	120	292	348	74	84,5	40	50	175	118	105,5	110,5	125	125	50	55	113	35	9	8,2
150	6	56	209	203	131	305	361	74	84,5	40	50	175	118	105,5	110,5	125	125	50	55	141	48	10	9,1
200	8	60	265	245,5	165	386	382	100	84,5	70	50	228	118	145	110,5	200	125	40	75	192	71	24,5	13,7
250	10	68	317	271	200	411,5	440	100	82,5	70	73	228	205	145	160	200	200	40	75	242	91,5	30,8	21
300	12	77	370	296	238	461,5	465	100	82,5	70	73	234	205	170	160	250	200	40	75	291	112	42,6	30,3

(1) SYLAX FM & (2) SYLAX CNPP : Ductile iron body (JS1030) ; Ductile iron disc (JS1030) , EPDM liner.

Tapped lugs

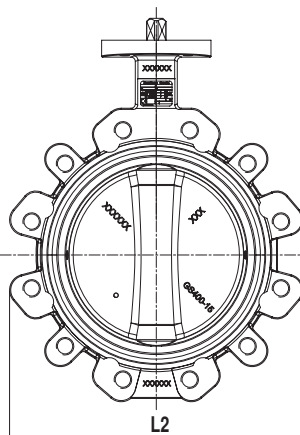

Diameter	Face to face	Overall dimensions						Iso top according to ISO 5211											Travel of the disc		Weight (kg)		
		DN	NPS	E	L2	H1	H2	H5	H6	A	A1	B	B1	C	C1	F	F1	G	G1	H	I	D1	D2
32	1 1/2	32	146	130	57	232	287	74	84,5	40	50	168	118	93	110,5	100	125	50	55	31	6,5	5,2	3,5
40	1 1/2	32	146	130	57	232	294	74	84,5	40	50	168	118	93	110,5	100	125	50	55	31	6,5	5,2	3,5
50	2	43	121	136	62	238	303	74	84,5	40	50	168	118	93	110,5	100	125	50	55	29	4,5	5,7	4,4
65	2 1/2	46	135	145	70	247	296	74	84,5	40	50	168	118	93	110,5	100	125	50	55	48	10	6,2	4,8
80	3	46	179	151	89	253	302	74	84,5	40	50	168	118	93	110,5	100	125	50	55	67	18	7,1	5,8
100	4	52	206	175	103	277	326	74	84,5	40	50	175	118	105,5	110,5	125	125	50	55	88	25	9,4	8,2
125	5	56	238	190	119	292	341	74	84,5	40	50	175	118	105,5	110,5	125	125	50	55	113	35	11,6	10,3
150	6	56	265	203	133	305	354	74	84,5	40	50	175	118	105,5	110,5	125	125	50	55	141	48	12,7	11,4
200	8	60	336	245,5	168	386	414,5	100	84,5	70	73	228	118	145	110,5	125	125	40	75	192	71	30,6	24,9
250	10	68	396	271	198	411,5	440	100	82,5	70	73	228	205	145	160	200	200	40	75	242	91,5	36,9	31,6
300	12	77	453	296	227	461,5	463,5	100	82,5	70	73	234	205	170	160	250	200	40	75	291	112	48,7	34,8

(1) SYLAX FM & (2) SYLAX CNPP : Ductile iron body (JS1030) ; Ductile iron disc (JS1030) , EPDM liner.

Extension shaft

Optional : extension shaft on Sylax CNPP version , maximum length 3 m : on request from our sales department.

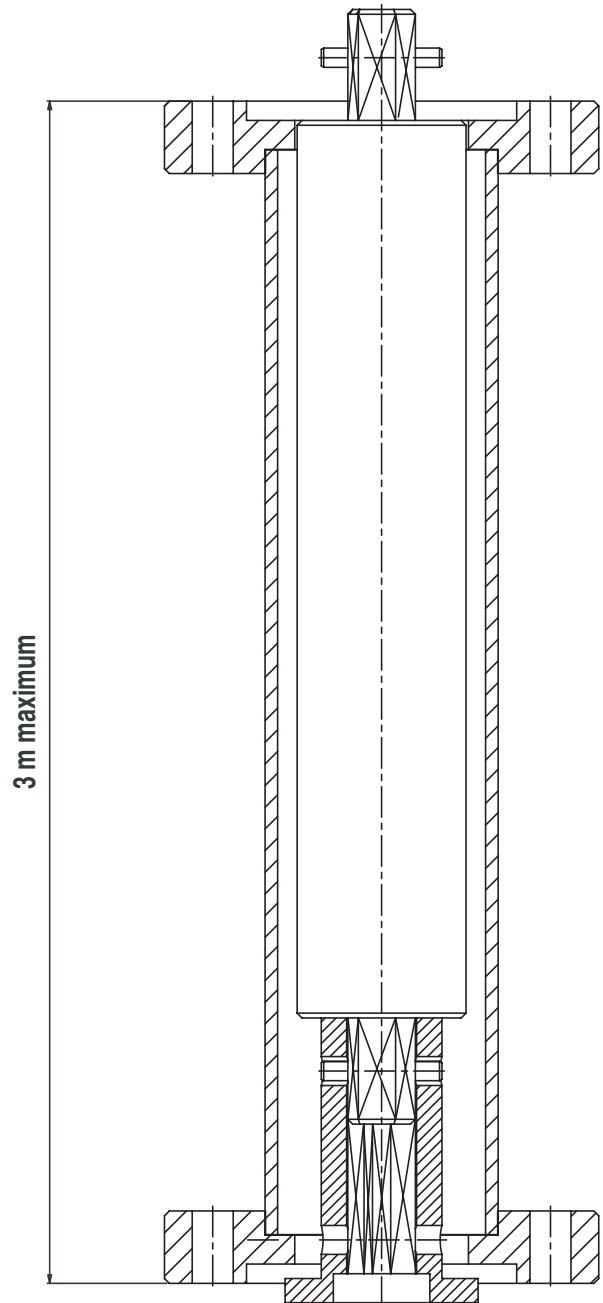
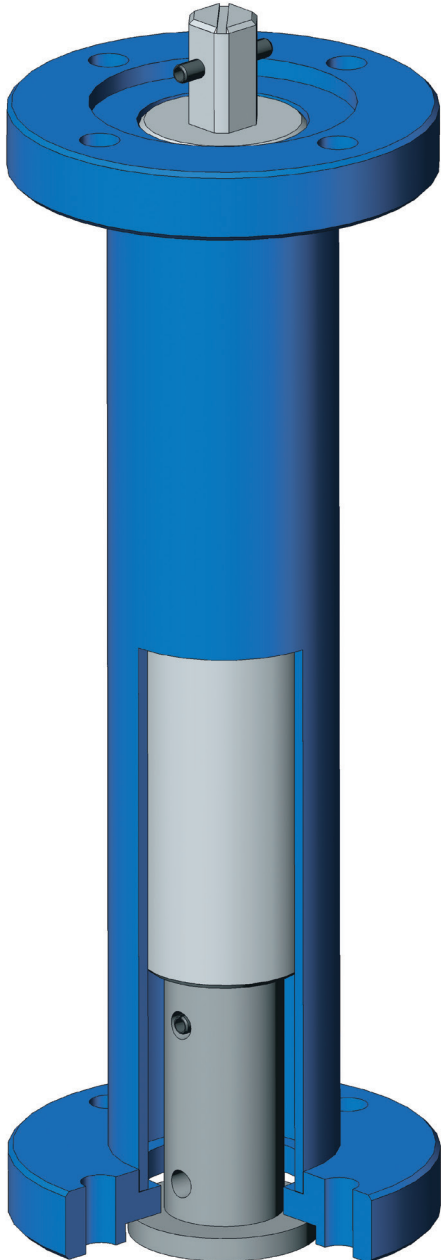

Electric wiring

CNPP version :

Position of limit switches for AB232-07LX and AB232-10 LX

Electric wiring SYLAX CNPP

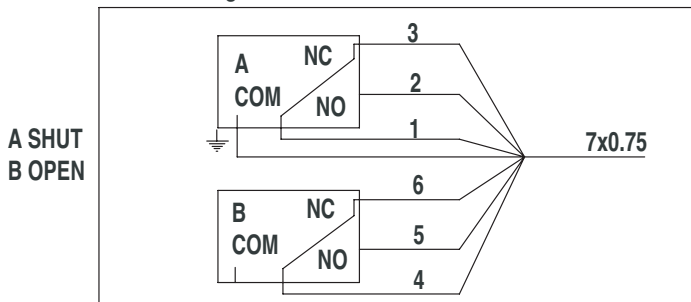

POSITION OF LIMIT SWITCHES AB232-07LX

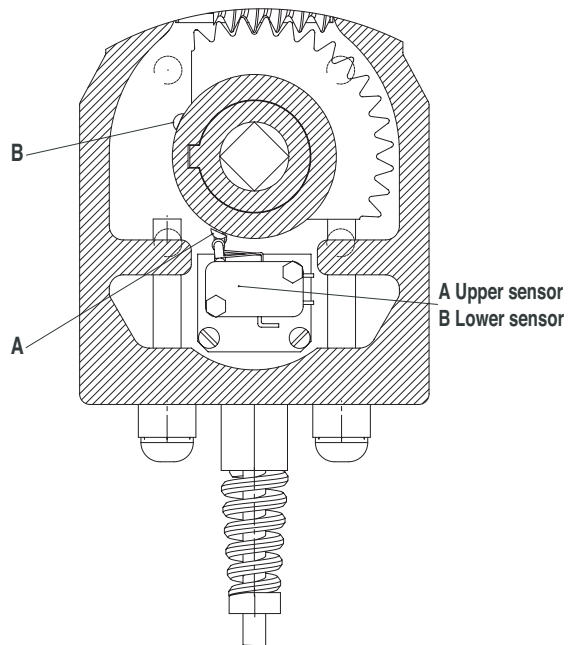

FM version :

Position of limit switches for AB150LX and AB550LX

POSITION OF LIMIT SWITCHES FOR AB150LX AND AB550LX

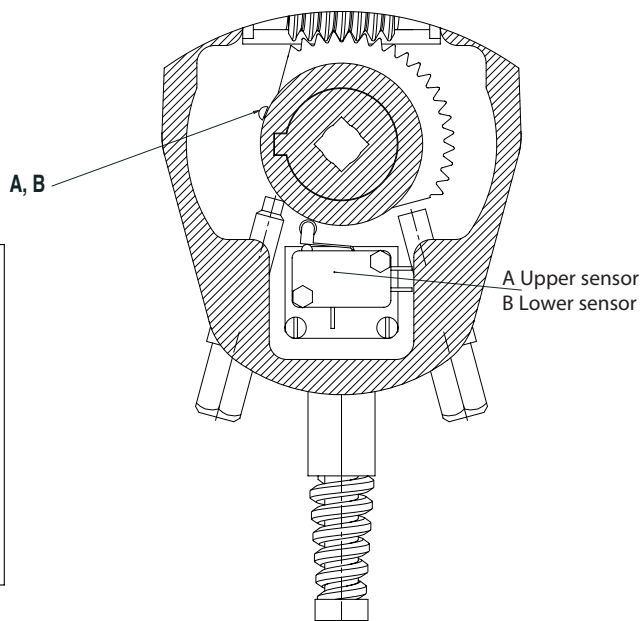
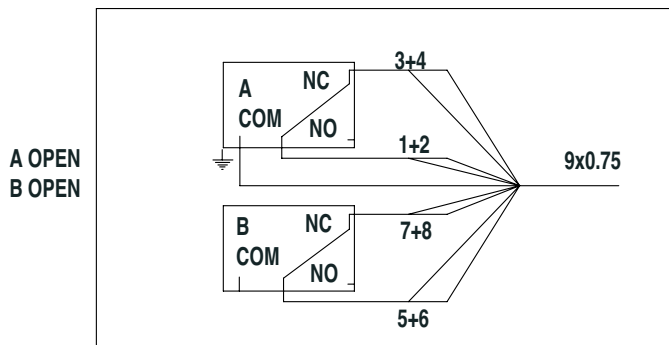

Connecting flanges

The valve type Sylax FM-CNPP can be mounted with the following connections (other types on request) :

- ✓ : possible mounting
- : possible mounting with re-machining
- : possible mounting but special reference
- : impossible mounting

• 4 Centring lugs

Diamètre		EN1092-1 & EN1092-2					ASME/ANSI B16.1 Class 125	ASME/ANSI B16.5 Class 150	ASME/ANSI B16.5 Class 300	BS10		JIS B2238 et JIS B2239		
DN	NPS	PN6	PN10	PN16	PN25	PN40				Table D	Table E	5K	10k	16k
32	1 1/4	✓	✓	✓	✓	✓	✓(1)	✓(1)	✓	●	●	●	✓	●
40	1 1/2	✓	✓	✓	✓	✓	✓	✓	●	✓	✓	●	✓	●
50	2	✓	✓	✓	✓	✓	✓	✓	●	✓	✓	●	●	●
65	2 1/2	✓	✓	✓	✓	✓	✓	✓	●	●	●	✓	✓	●
80	3	✓	✓	✓	✓	✓	✓	✓	●	✓	✓	✓	●	●
100	4	✓	✓	✓	✓	✓	✓	✓	●	✓	✓	●	●	✓
125	5	✓	✓	✓	●	●	✓	✓	●	✓	✓	✓	✓	●
150	6	✓	✓	✓	●	●	✓	✓	●	✓	✓	✓	✓	●
200	8	✓	✓	✓	●	●	✓	✓	●	✓	✓	●	●	●
250	10	✓	✓	✓	●	●	✓	✓	■	●	✓	✓	✓	●
300	12	✓	✓	✓	✓	●	✓	✓	●	✓	✓	✓	✓	✓

(1) Re-machining for ductile iron body GJS 400-15 (JS1030)

• Tapped lugs

Diamètre		EN1092-1 & EN1092-2					ASME/ANSI B16.1 Class 125	ASME/ANSI B16.5 Class 150	ASME/ANSI B16.5 Class 300	BS10		JIS B2238 et JIS B2239		
DN	NPS	PN6	PN10	PN16	PN25	PN40				Table D	Table E	5K	10k	16k
32	1 1/4	○	✓	✓	✓	✓	○	○	○	○	○	○	○	○
40	1 1/2	○	✓	✓	✓	✓	○	○	○	○	○	○	○	○
50	2	○	✓	✓	✓	✓	○	○	■	○	○	○	○	○(4)
65	2 1/2	○	✓	✓	○	○	○	○	■	○	○	○	○	○
80	3	○	✓	✓	✓	✓	○	○	■	○	○	○	○	○
100	4	○(5)	✓	✓	○	○	○	○	■	○(5)	○	○	○	○
125	5	✓	✓	✓	✓	✓	✓	✓	✓	✓	✓	✓	✓	✓
150	6	✓	✓	✓	✓	✓	✓	✓	✓	✓	✓	✓	✓	✓
200	8	✓	✓	✓	■	■	○	○	■	○	○	○	○	○(1)
250	10	○	✓	✓	○	○	○	○	■	○	○	○	○	○
300	12	○	✓	✓	■	■	○	○	■	○	○	○	○	○

DN65 PN10/16 4 holes

(1) corps JS1030

4) Possible mounting for ductile iron body GJS 400-15 (JS1030)

5) Possible mounting if the butterfly valve is inclined at 22,5°

Attention : the lug type body is not a multi-connection body (connection to many flanges of different sizes). Generally, every connection relates to a different reference of finished products.

• End of line mounting and downstream removing

The end of line mounting and the downstream removing, at ambient temperature, of the Sylax FM-CNPP is limited to the pressure mentioned on page 11 according to the PED directive 2014/68/UE .

These mountings are only possible on tapped lug bodies

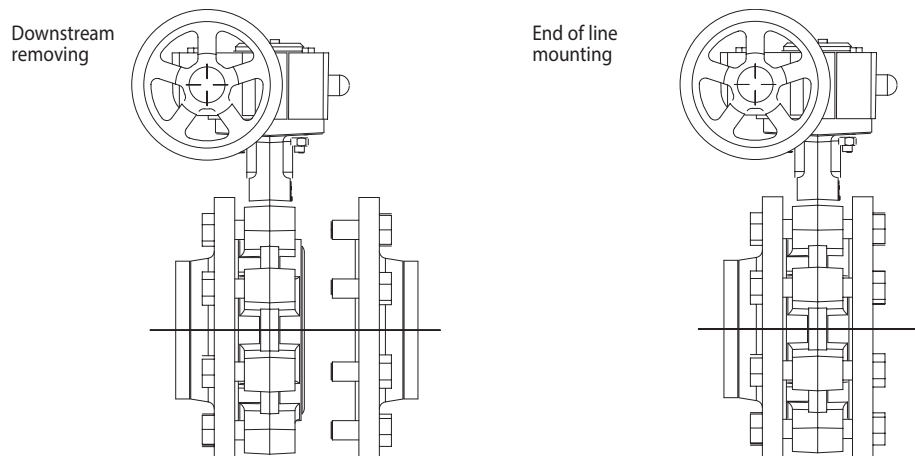

Normalisation

- **Design :**
According to EN 593 and marking according to EN 19
- **Iso top connection for actuations :**
According to EN ISO 5211
- **Face to face :**
According to 558-1 series 20
ISO 5752 series 20
API 609 table 2
- **Connecting flanges :** see on page 10
According to EN1092-1 and EN1092-2
ASME/ANSI B16.5
BS10-d and BS10-e
JIS B2238 and JIS B2239
- **Tests :**
According to EN12266-1
Resistance and tightness of the body : test P11(1,5 x allowable operating pressure)
Tightness of the seat : test P12 rate A (1,1 x allowable operating pressure)
- **European Directive :**
Our butterfly valves are in accordance to the safety requirements of the following directive. :

Directive 2014/68/UE : Equipments under pressure PED (Pressure Equipment Directive)

Applies to the design, manufacturing and the assessment of the conformity of pressure equipment, the maximum allowable pressure of which is 0.5 bar.

Pressure equipment for water supply, distribution, and disposal of water is excluded.

Depending on the type of pressure equipment, maximum allowable temperature (PS), DN, physical nature of the fluid (liquid, gas or vapour) and the degree of danger of the fluid (group1/2)*, the directive classifies this same equipment into different categories (article 3.3, I, II, III, IV), required for the assessment of conformity with CE marking.

The equipment defined in article 3.3 of the directive must not bear the CE marking.

(*) Group 1 : hazardous fluids (directive 67/548/EEC) / explosive / highly flammable /easily flammable / flammable / very toxic / toxic / combustion agents.

Group 2 : all other fluids

Important notice : the indicated pressure for the different categories of fluids (L1/L2/G1/G2) is under no condition a guarantee of use.

Therefore, it is essential to validate the use of products under given operating conditions. Socla is not responsible for alterations of the products to working conditions not previously specified by the customer.

In order to facilitate your choice regarding these new regulatory requirements, Socla has put the necessary information concerning products with CE marking, specification sheets and product identification plates at your disposal in the price list (+ see additional explanations on the detachable slip).

In addition, the operating instructions are available on our web site www.socla.com or by simple request from our sales department.

An instruction notice specifying the installation characteristics and the commission of the Sylax FM-CNPP is available on our web site www.socla.com or on request by our sales department.

Pressure
DIRECTIVE 2014/68/UE Equipments under pressure.

Products manufactured in conformity with the requirements of the directive, according to pressure, DN and fluid (see on the precedent page).

LINERS		DN mm	Cat.	MOUNTING	PFA	PS			
						L1	L2	G1	G2
16 bar	EPDM (CNPP Approval), EPDM (FM Approval)	32 to 300	4.3	Flanges	16		16		
				End of line	12		12		

PS : Maximum allowable pressure (in bar) according to Directive 2014/68/UE

PFA : Allowable operating pressure (in bar) for supply, distribution and disposal of water.

Torque values

<i>Torques for water in Nm EPDM</i>	32/40	50	65	80	100	125	150	200	250	300
PS16	15	18	30	32	50	83	115	180	280	430
PS16 CNPP	15	15	20	26	45	53	66	123	295	346

One actuation minimum per month.

Flow rate (Kv)

OPENING STAGE - Stainless steel disc

DN	10°	20°	30°	40°	50°	60°	70°	80°	90°
32/40	-	-	-	5	12	25	40	56	62
50	-	-	1	8	18	33	54	71	79
65	-	-	6	19	41	76	118	158	174
80	-	3	18	43	79	138	211	252	275
100	-	15	38	83	154	253	368	458	496
125	-	20	61	134	249	399	599	792	883
150	5	37	100	200	374	600	863	1109	1212
200	15	76	200	399	680	1099	1666	2196	2500
250	40	150	333	621	1084	1765	2652	3517	3948
300	60	219	500	989	1736	2770	4097	5118	5635

The butterfly valve is not the best product for regulating. Nevertheless, the Sylax FM-CNPP butterfly valve can be used to regulate by an opening stage between 30° and 90°.

A regulation in the opening stage lower than 30° is not advisable because of over speed, cavitation effect, which could damage prematurely the valve.

Kv = volume of water in m³/h through a valve at a preset opening stage and under a head loss of 1 bar.

The maximum flow velocity of the fluid through the valve must not exceed :
 - 3 m/s for liquid fluids. Between 3 and 5m/s, the use of the Sylax FM-CNPP butterfly valve is possible, but the phenomena of cavitation, noise, vibration and water hammering increase..

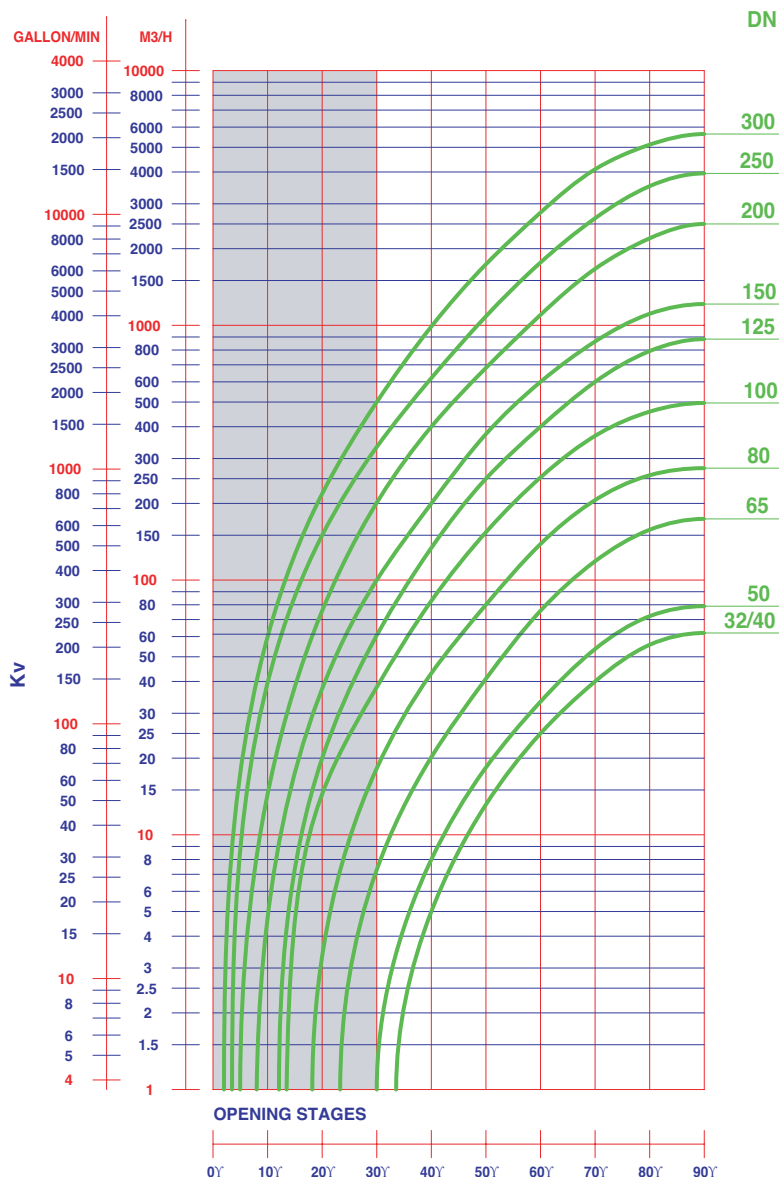

Head loss diagram (Δp)

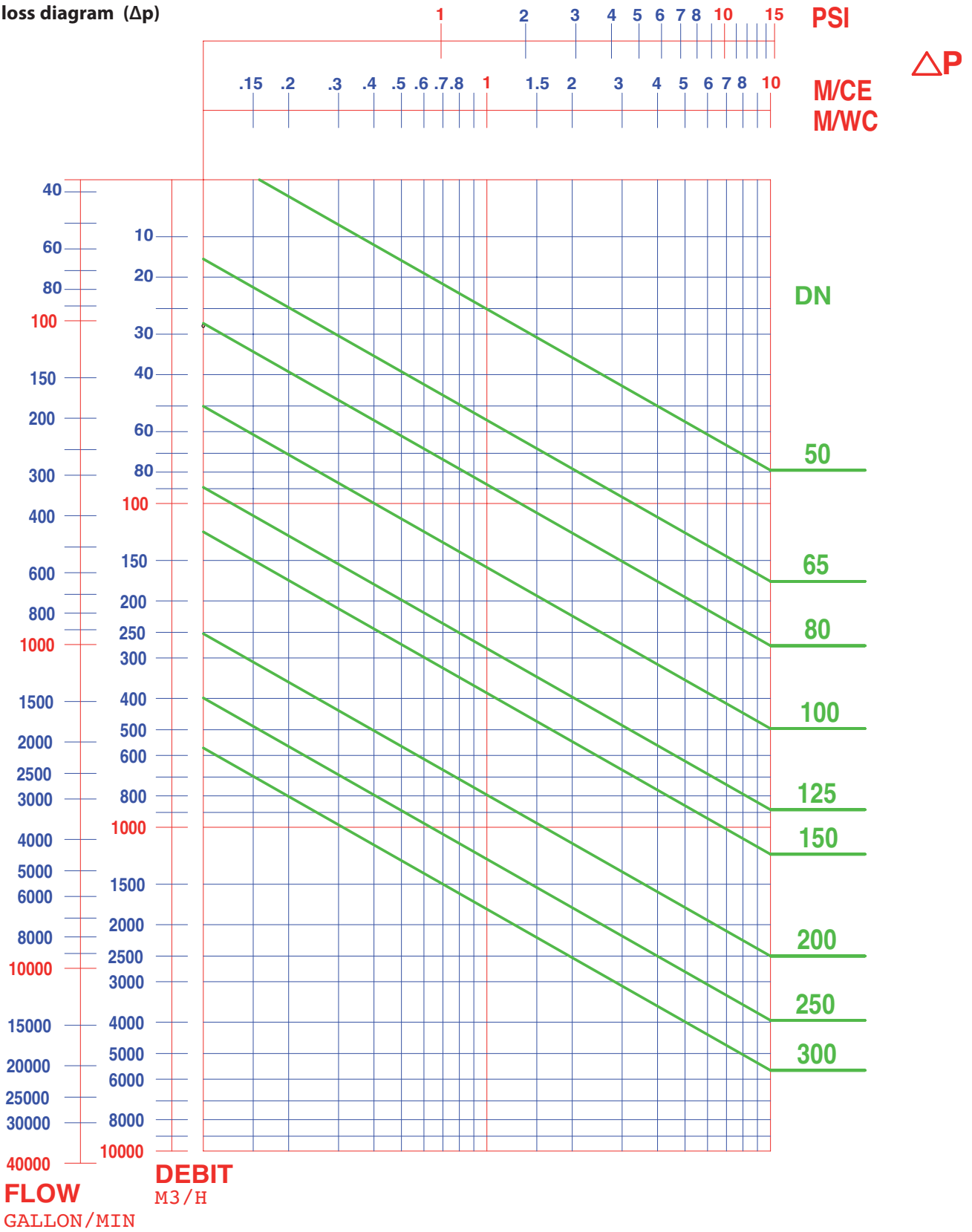

Type of flange

The Sylax FM-CNPP butterfly valve has been designed to be mounted on standard flanges. Only standard flanges type 11, 21 and 34 according to EN 1092 are quite compatible.

For other types of flanges, refer to the table below. Non appropriate connections will cancel our guarantee.

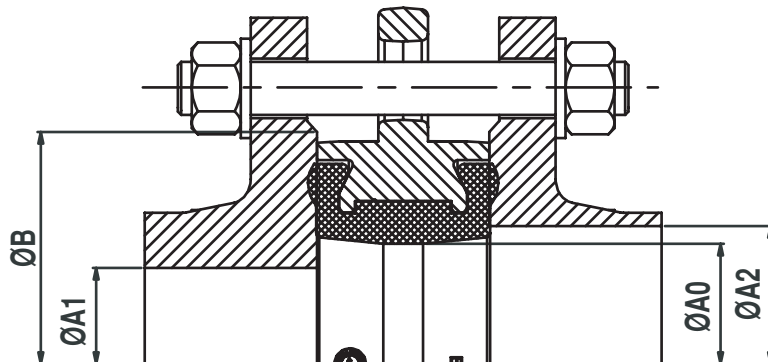

DN		Ø A0	Ø A1 mini	Ø A2 maxi	Ø B mini
32/40	1 1/4	43	35	51	80
50	2	54	42	60	90
65	2 1/2	70	62	74	110
80	3	85	82	91	128
100	4	100	97	108	148
125	5	125	128	143	178
150	6	150	156	166	202
200	8	200	200	224	258
250	10	250	252	280	313
300	12	300	303	329	365

NOTE:
The use of expansion seals, as well as the use of elastomer coated flanges, between the flange and the valve are strictly forbidden.

Tag / traceability



Rep	Description
1	Name of the valve
2	Reference
3	Material of the disc
4	Material of the liner
5	Pressure PFA water 20°C
6	Number of manufacturing order
7	Manufacturing date
8	Connecting flanges

FM approval tag riveted on gear box

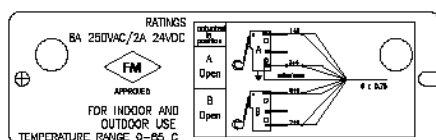

Bolts and nuts
Note : Bolts and nuts are not part of our standard supply.

DN	NPS	a	e	EN 1092 PN6			EN 1092 PN10			EN 1092 PN16			EN 1092 PN25			ASME / ANSI B16.5 Class 150		
				* Nb rods or Nb screw	ØV	c	* Nb rods or Nb screw	ØV	c	* Nb rods or Nb screw	ØV	c	* Nb rods or Nb screw	ØV	c	* Nb rods or Nb screw	ØV UNC**	c
32/40	1 1/2	32	14	4	M12	18	4	M16	24	4	M16	24	4	M16	24	4	1/2"	18
50	2	43	18	4	M12	18	4	M16	24	4	M16	24	4	M16	24	4	5/8"	24
65*	2 1/2	46	20	4	M12	18	8*	M16	24	8*	M16	24	8	M16	24	4	5/8"	24
80	3	46	20	4	M16	24	8	M16	24	8	M16	24	8	M16	24	4	5/8"	24
100	4	52	24	4	M16	24	8	M16	24	8	M16	24	8	M20	26	8	5/8"	24
125	5	56	26	8	M16	24	8	M16	24	8	M16	24	8	M24	32	8	3/4"	26
150	6	56	26	8	M16	24	8	M20	26	8	M20	26	8	M24	32	8	3/4"	26
200	8	60	28	8	M16	24	8	M20	26	12	M20	26	12	M24	32	8	3/4"	26
250	10	68	32	12	M16	24	12	M20	26	12	M24	32	12	M27	32	12	7/8"	26
300	12	78	36	12	M20	26	12	M20	26	12	M24	32	16	M27	32	12	7/8"	26

* For flanges in cast or ductile iron 4 holes M16 and for flanges in steel 8 holes M16 on the same drilling circle.

DN	NPS	a	e	BS10-d			BS10-e			JIS2238 & JIS2239 5K			JIS2238 & JIS2239 10K			JIS2238 & JIS2239 16K		
				* Nb rods or Nb screw	ØV UNC	c	* Nb rods or Nb screw	ØV UNC	c	* Nb rods or Nb screw	ØV	c	* Nb rods or Nb screw	ØV	c	* Nb rods or Nb screw	ØV	c
32/40	1 1/2	32	14	4	1/2"	18	4	1/2»	18	4	M12	18	4	M16	24	4	M16	24
50	2	43	18	4	5/8"	24	4	5/8»	24	4	M12	18	4	M16	24	8	M16	24
65	2 1/2	46	20	4	5/8"	24	4	5/8»	24	4	M12	18	4	M16	24	8	M16	24
80	3	46	20	4	5/8"	24	4	5/8»	24	4	M16	24	8	M16	24	8	M20	26
100	4	52	24	4	5/8"	24	8	5/8»	24	8	M16	24	8	M16	24	8	M20	26
125	5	56	26	8	5/8"	24	8	5/8»	24	8	M16	24	8	M20	26	8	M22	26
150	6	56	26	8	5/8"	24	8	3/4»	26	8	M16	24	8	M20	26	12	M22	26
200	8	60	28	8	5/8"	24	8	3/4»	26	8	M20	26	12	M20	26	12	M22	26
250	10	68	32	8	3/4"	26	12	3/4»	26	12	M20	26	12	M22	26	12	M24	32
300	12	78	36	12	3/4"	26	12	7/8»	26	12	M20	26	16	M22	26	16	M24	32

* WAFER TYPE BODY, :

Assembly by rods : number of nuts and washer = 2 x Number of rods (above)

Assembly by bolts : Number of nuts = Number of screws (above) and number of washer = 2 x Number of nuts

* LUG TYPE BODY :

Assembly by screws : Number of screw per face (above) and number of washer is the same

** ASME / ANSI B16.5 Class 150 : ØV UNC threading in inch ; for metric threading, please consult us.

Bolts and nuts

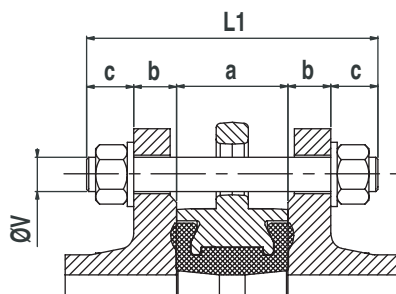

For wafer type body ; assembly by rods :

L1 = a + 2(b+c)

- L1 = minimum length of rods
- a = width of the butterfly valve (face to face dimension)
- b = thickness of the flange (customer)
- c = thickness of washer + thickness of nut + exceeding length of the rod.

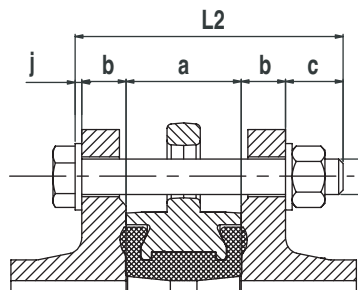

For wafer type body ; assembly by bolts :

L2 = a + 2b + c + j

- L2 = minimum length of rods
- a = width of the butterfly valve
- b = thickness of the flange (customer)
- c = thickness of washer + thickness of nut + exceeding length of the rod
- j = thickness of washer at the head of the screw.

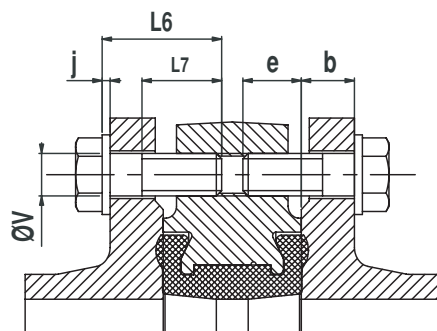

For lug type body ; assembly by screws :

L5 ≤ b + e + j avec L6 ≥ L5 - (b + j)

- L5 = maximum length under head of screw
- L6 = minimum length of the threading of the screw
- a = width of the butterfly valve (face to face dimension)
- b = thickness of the flange (customer)
- e = maxi depth of screw
- j = thickness of washer

Installation

• General remarks :

For safety reasons, the installation must take place under the supervision of authorised people taking account of local safety instructions and advice.

The handling of butterfly valves and their controls must be done by staff trained in all technical aspects of their operation.

Before installation the pipes must be depressurised and purged (empty of its fluid) in order to avoid any danger to the operator.

The pipe work must be correctly aligned so that no extra stress is exerted on the valve casing.

Check the compatibility of the connection flanges against the operating pressure : the PN number of the flanges must be greater or equal to the operating pressure.

The valve is a machined piece of equipment and must not be used to prise apart the flanges.

An **instruction notice** specifying the installation characteristics and the commission of the Sylax FM-CNPP is added to every product. It is available on our web site www.socla.com or on request by our sales department.

• Installation conditions :

It is recommended that the distances mentioned below be respected in order to prolong the life time of the valve.

Mounting the valve close to pipe work junctions places it in turbulent zones which increase its wear.

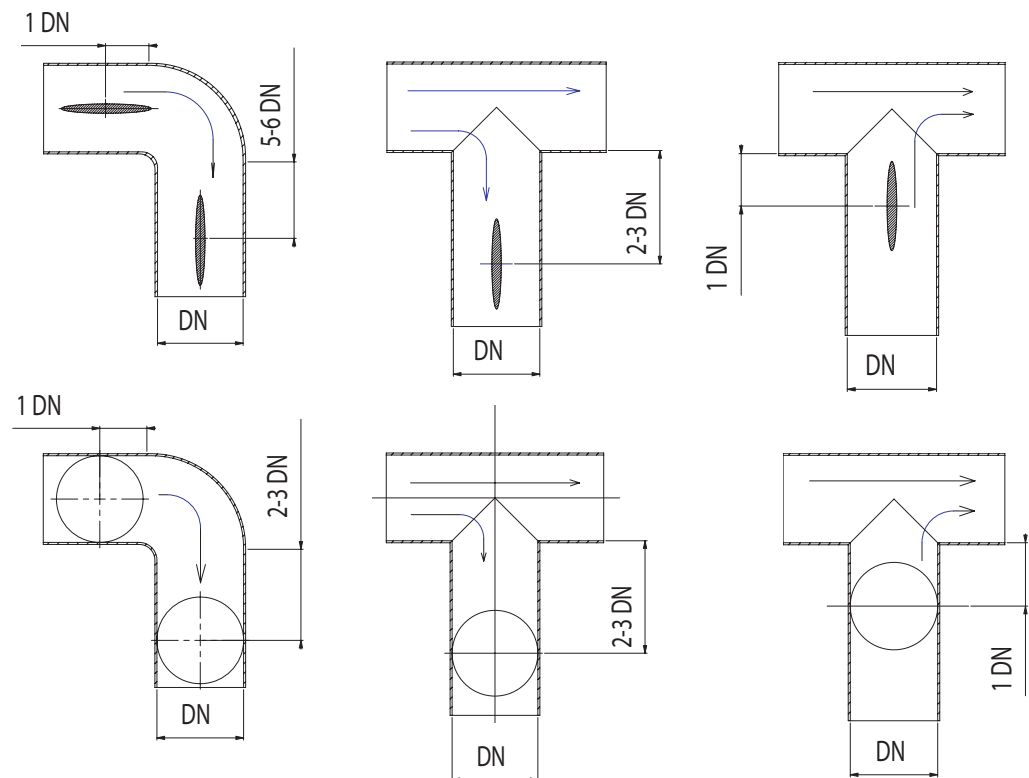

Socla can accept no responsibility for possible errors in catalogue, brochures and other printed material. Socla reserve the right to alter its products without notice. This also applies to products already agreed. All trademarks in this material are the property of the respective companies. All right reserved.

Socla SAS

365 rue du lieutenant Putier
 71530 VIREY LE GRAND
 Postal address : CS 10273
 71107 CHALON SUR SAONE Cedex

Tel : 33 3 85 97 42 52
 Fax : 33 3 85 97 97 42
<http://www.socla.com>
 e-mail:contact@socla.com