

HF49

Sludge and Air Separator

for heating systems

APPLICATION

The sludge and air separator serves to separate sludge and air from the heating system. It is equipped with a sludge and contamination reduction feature that functions according to the cyclone principle. This guarantees an effective separation of the particles.

There is an optional phosphate cartridge available to prevent corrosion in aluminium-free heating systems.

SPECIAL FEATURES

- Swivel connection for vertical or horizontal installation
- Integrated magnet for separation of ferromagnetic metals
- Integrated quick bleeder
- Quality insulation shell to prevent heat loss

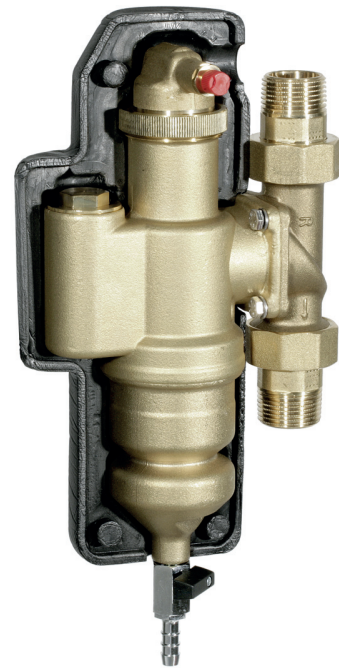

TECHNICAL DATA

Connections / Sizes	
Connection size:	DN25
Pressure values	
Max. inlet pressure with clear filter bowl:	16 bar
Max. inlet pressure with brass filter bowl:	25 bar
Max. operating pressure:	10 bar
Nominal pressure:	10 bar
Nominal flow:	3.6 m ³ /h
Pressure loss during nominal flow rate:	0.2 bar
Operating temperatures	
Max. operating temperature medium:	90 °C

CONSTRUCTION

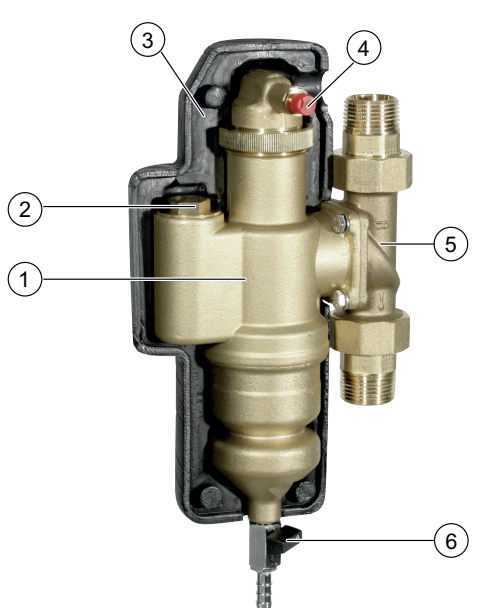
Overview	Components	Materials
	1 Housing	Dezincification-resistant brass
	2 Blind plug including magnetic separator	
	3 Insulation shells	PE foam
	4 Quick bleeder	Dezincification-resistant brass
	5 Connection piece	Dezincification-resistant brass
	6 Ball valve	
Not depicted components:		
	Seals	EPDM

METHOD OF OPERATION

The heater water separator serves to separate sludge and air from the heater system.

It is equipped with a sludge and contamination reduction that functions according to the cyclone principle. This guarantees an effective separation of the particles.

The heater water separator is equipped with a quick bleeder for the air separation. If there is air in the system, it will rise to the highest point of the heater water separator. The water level drops there, the integrated floater pulls the floater arm down and thereby opens the sealed area. The air bleeds out whereby the water level rises again and the sealed area is closed again.

The optionally available phosphate cartridge counters the corrosion in the heater system. This dosing serves as an additional protection of the heater system; not as a replacement of the basic conditioning of the heater water by inhibitors.

TRANSPORTATION AND STORAGE

Keep parts in their original packaging and unpack them shortly before use.

The following parameters apply during transportation and storage:

Parameter	Value
Environment:	clean, dry and dust free
Min. ambient temperature:	-15 °C
Max. ambient temperature:	+70 °C
Min. ambient relative humidity:	25 % *
Max.ambient relative humidity:	95 % *

*non condensing

INSTALLATION GUIDELINES

Setup requirements

- The sludge and air separator is not suited for:
 - The separation of oils greases, solvents, soaps and other lubricating media
 - The separation of water-solvent materials
- The sludge and air separator is installed in the heating circuit (feed and return line)
- The heating system needs to be rinsed and filled
- The national installation regulations, general guidelines and technical data must be observed during the assembly
- The installation site has to be frost-proof and the protection of the device from chemicals, paints, detergents, solvents and their vapours and environmental influences must be guaranteed
- A course dirt separator needs to be installed up front for water with course dirt particles
- To ensure the bleeding of the air, the sludge and air separator has to be installed with the quick bleeder upwards
- The separator has to stand vertically; the connection piece can be built into horizontal and vertical lines
- Make sure the seals fit properly. The pressure-sealing tightening of the screws has to be done cross-wise
- Install stop valves ahead and following the sludge and air separator
 - This makes it possible to maintain the sludge and air separator easily without draining the heating system
- Mount the sludge and air separator at easily accessible points in the system

Installation Example

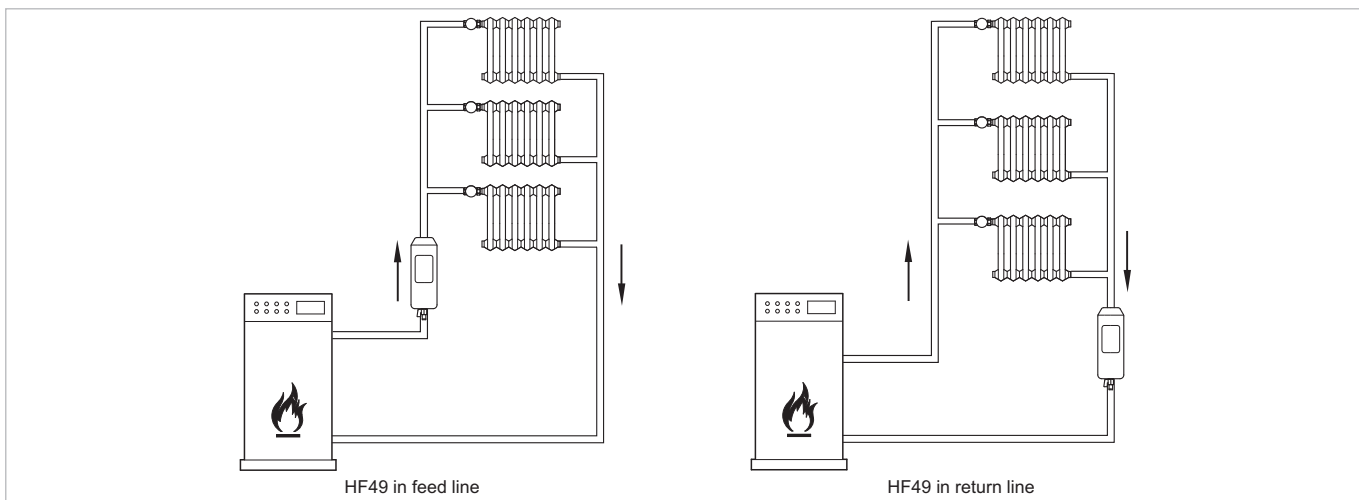

Fig. 1 Standard installation example for the sludge and air separator

TECHNICAL CHARACTERISTICS

kvs-Values

Connection sizes:	25
kvs-value (m ³ /h):	7.8

DIMENSIONS

Overview

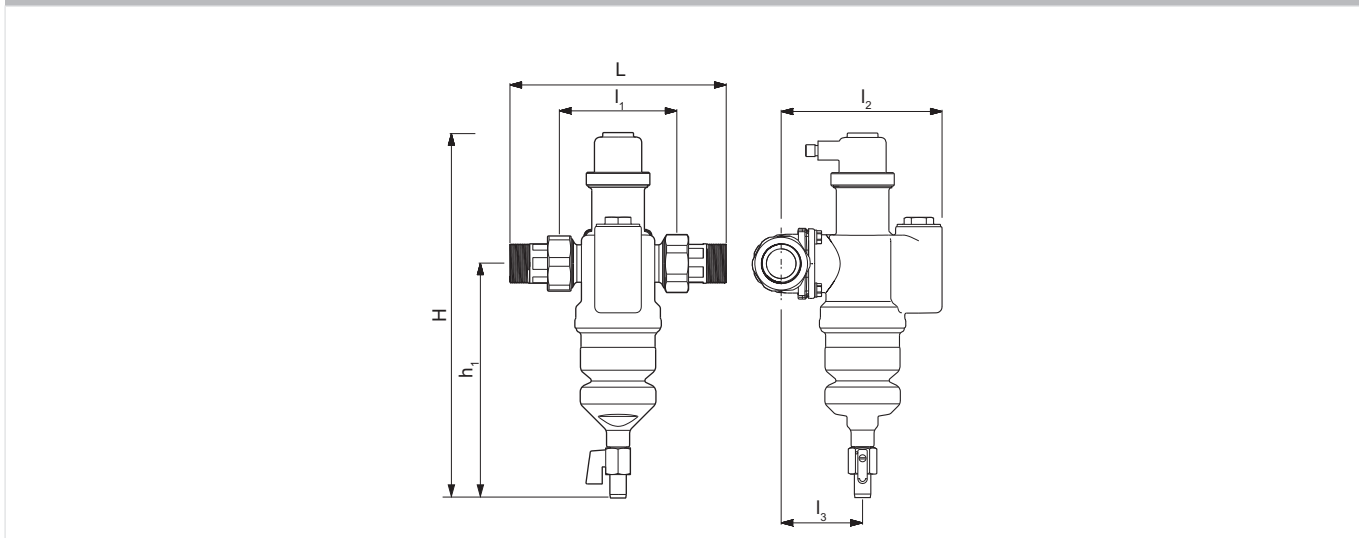

Parameter		Values
Dimensions:	mm	
	H	330
	h ₁	310
	L	184
	l ₁	100
	l ₂	138
	l ₃	70
Weight:	kg	3.35

ORDERING INFORMATION

The following tables contain all the information you need to make an order of an item of your choice. When ordering, please always state the type, the ordering or the part number.

Options

The valve is available in the following sizes: 1/2".

- standard
- not available

		HF49-1A
Connection type:	Standard version:	•

Accessories

	Description	Dimension	Part No.
	PE49 Phosphate cartridge		
	Phosphate cartridge for protection of the heater system against corrosion. Use only in heater systems without aluminium materials.		PE49

Spare Parts

Refilling combination HF49, from 2008 onwards

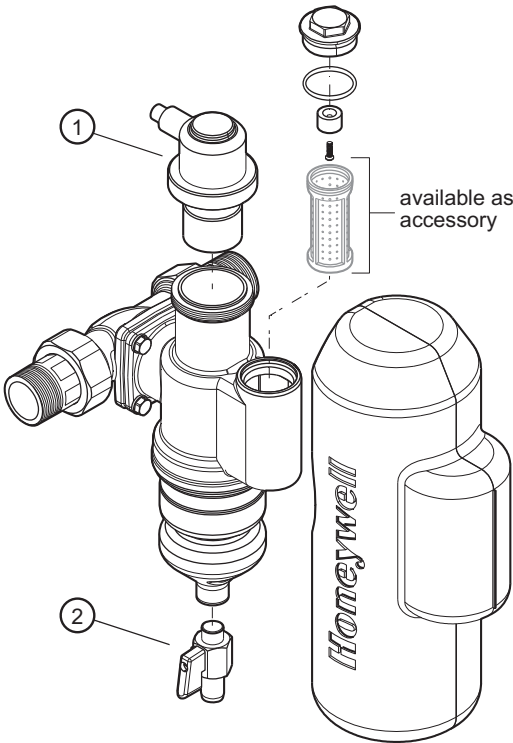
Overview	Description	Dimension	Part No.	
	1 Venting insert		EE49	
	2 Venting insert		KH49	

Environmental & Energy Solutions

Honeywell GmbH
 Hardhofweg
 74821 MOSBACH
 GERMANY
 Phone: (49) 6261 810
 Fax: (49) 6261 81309
<http://ecc.emea.honeywell.com>

Manufactured for and on behalf of the
 Environmental and Combustion Controls
 Division of Honeywell Technologies Sàrl, Z.A.
 La Pièce 16, 1180 Rolle, Switzerland
 by its Authorised Representative Honeywell GmbH
 ENOH-1549GE23 R0916
 Subject to change
 © 2016 Honeywell GmbH