



FV300

Filling valve

APPLICATION

Filling valve of this type can be used in water supplies and for industrial and commercial applications for the filling of reservoirs, tanks and cisterns. It is controlled by the main storage medium via a float valve and impulse link pipework.

Filling valve of this type is prevented from filling constantly by the use of a pilot valve, which can be adjusted to provide varying fill level differentials for opening and closing the valve.

APPROVALS

- DVGW
- WRAS (up to 23 °C)

SPECIAL FEATURES

- High flow capacity
- Powder-coated inside and outside - Powder used is physiologically and toxicologically safe
- Integral control circuit and ball valves
- Integral fine filter
- No external energy required for operation
- Compact construction
- Light weight



TECHNICAL DATA

Media	
Medium:	Drinking water
Connections/Sizes	
Connection size:	DN50 - DN450
Pressure values	
Max. operating pressure:	16 bar
Nominal pressure:	PN16
Minimum pressure:	0.7 bar + pressure resulting from differential in physical height of the impulse link pipe
Operating temperatures	
Max. operating temperature medium:	80 °C
Specifications	
Switching level differential:	with Pilot float valve 70 - 550 5 - 40 cm with Pilot float valve 70 - 610 5 - 40 cm

CONSTRUCTION

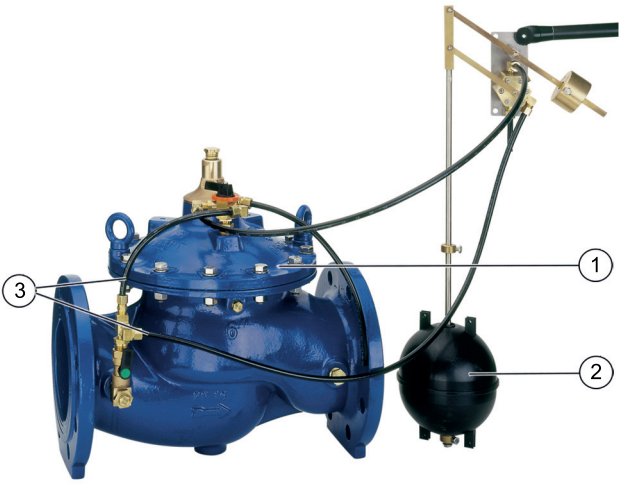
Overview	Components	Materials	
	1	Housing with flanges acc. to ISO 7005-2 / EN 1092-2	Ductile iron (ISO 1083), powder-coated
	2	2 Pilot float valves 70 - 550 and 70 - 610	High-quality synthetic material spherical Brass float valve housing
	3	Control circuit with integral rinsable filter insert and ball valves on inlet and outlet	High-quality synthetic material
	Not depicted components:		
		Cover plate	Ductile iron (ISO 1083), powder-coated
		Diaphragm plate	Ductile iron (ISO 1083), powder-coated
		Diaphragm	EPDM
		Spring	Stainless steel
		Regulating cone	Stainless steel
		Valve seat	Stainless steel
	Compression fittings	Brass	
	Pilot valve housing	Brass	
	Filter insert	Stainless steel	
	Seals	EPDM	

METHOD OF OPERATION

At zero pressure conditions the diaphragm valve is closed. If flow is opened to the filling valve of this type, water enters the inlet area and the increasing pressure opens the valve so that water in the outlet area can flow into the container. If the water level in the container reaches the preset level, then the float valve closes. The inlet pressure in the diaphragm chamber increases and closes the diaphragm valve. If the water level in the container falls, the float valve opens, the pressure in the diaphragm chamber falls and the inlet pressure opens the diaphragm valve for as long as the set water level in the container is not reached.

TRANSPORTATION AND STORAGE

Keep parts in their original packaging and unpack them shortly before use.

The following parameters apply during transportation and storage:

Parameter	Value
Environment:	clean, dry and dust free
Min. ambient temperature:	5 °C
Max. ambient temperature:	55 °C
Min. ambient relative humidity:	25 % *
Max. ambient relative humidity:	85 % *

*non condensing

INSTALLATION GUIDELINES

Setup requirements

- Install shut-off valves
- Install downstream of the strainer
 - Protects against damage from coarse particles
 - Note flow direction (indicated by arrow)
- The installation location should be protected against frost and be easily accessible
 - Pressure gauge can be read off easily
 - Simplified maintenance and cleaning
- Provide a straight section of pipework of at least five times the nominal valve size after the pressure reducing valve (in accordance with EN 806-2)
- Safety valve SV300 optional
- Requires regular maintenance in accordance with EN 806-5

Installation Example

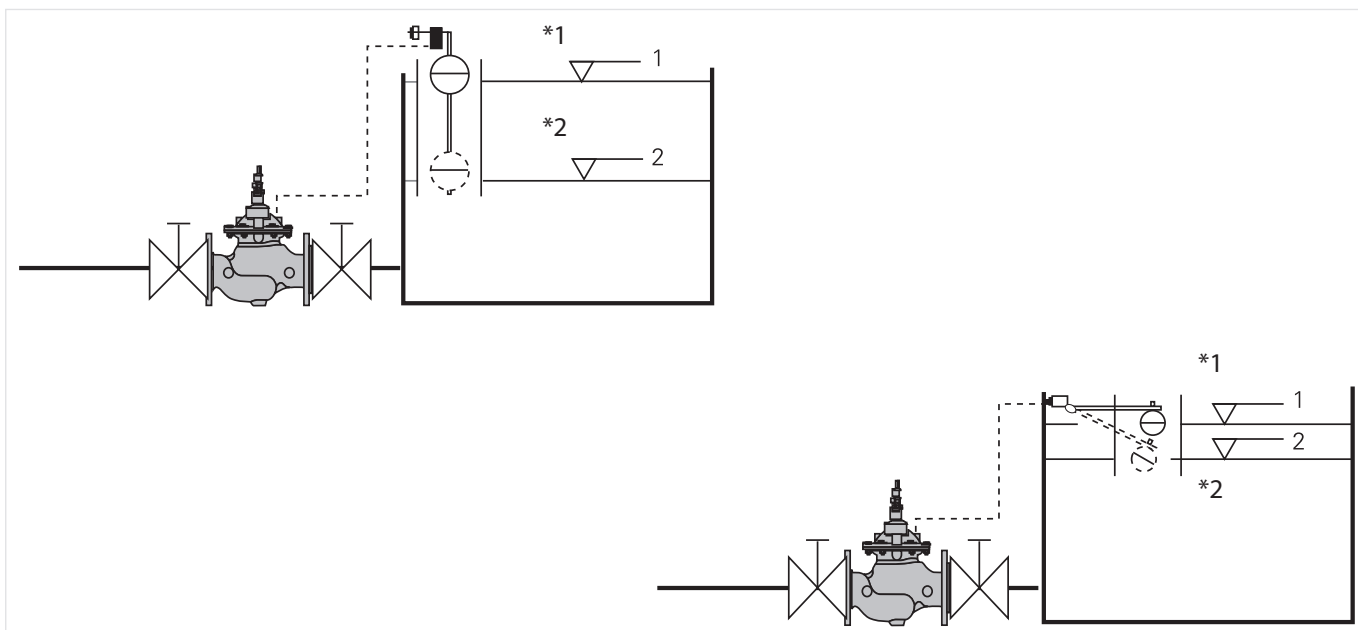

Fig. 1 Standard installation example for the filling valve

*1 closed

*2 open

Connection sizes:	2"	2 1/2"	3"	4"	6"	8"	10"	12"	14"	16"	18"
Distance in mm (W*):	100	110	120	130	160	190	220	250	270	310	330

* Required installation distances between the centerline of the pipework and the surrounding in dependency of the connection size.

TECHNICAL CHARACTERISTICS

kvs-Values

Connection sizes:	50	65	80	100	150	200	250	300	350	400	450
k _{vs} -value (m ³ /h):	43	43	103	167	407	676	1160	1600	2000	3000	3150
Flow rate (Q _{max}) in m ³ /h - V=5.5 m/s:	40	40	100	160	350	620	970	1400	1900	2500	3100

Pressure drop characteristics

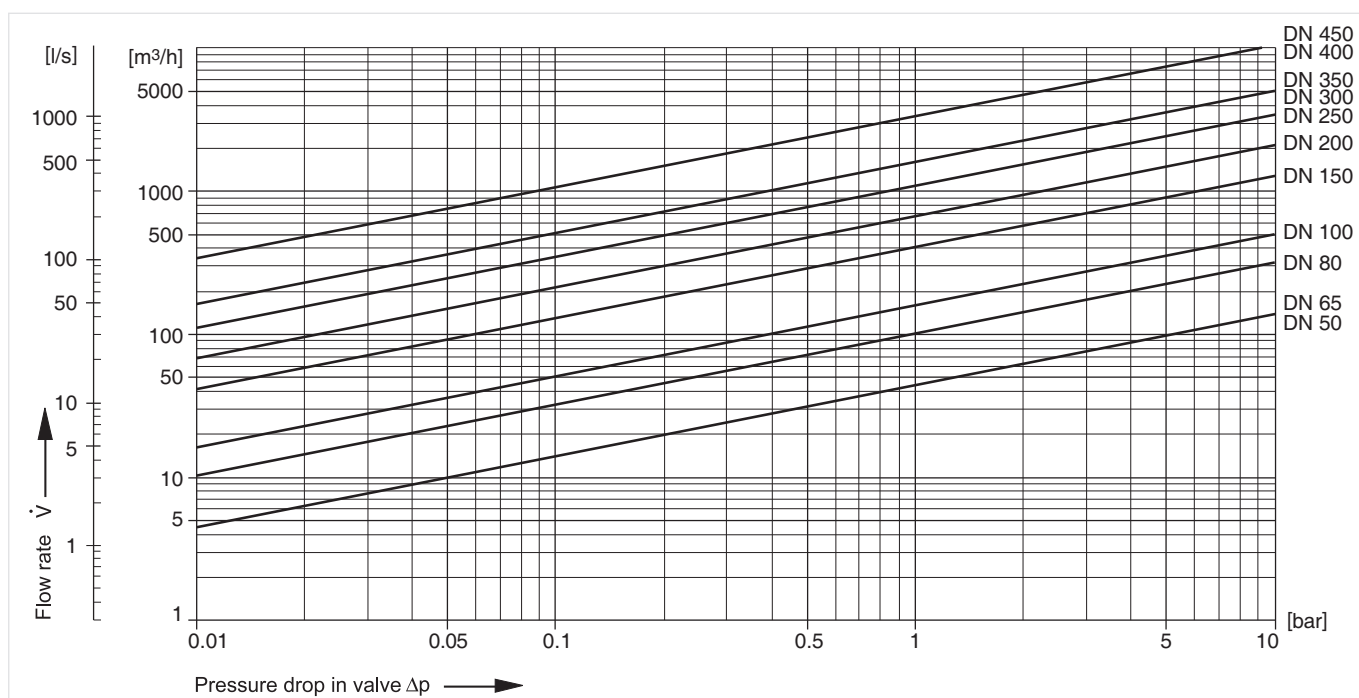
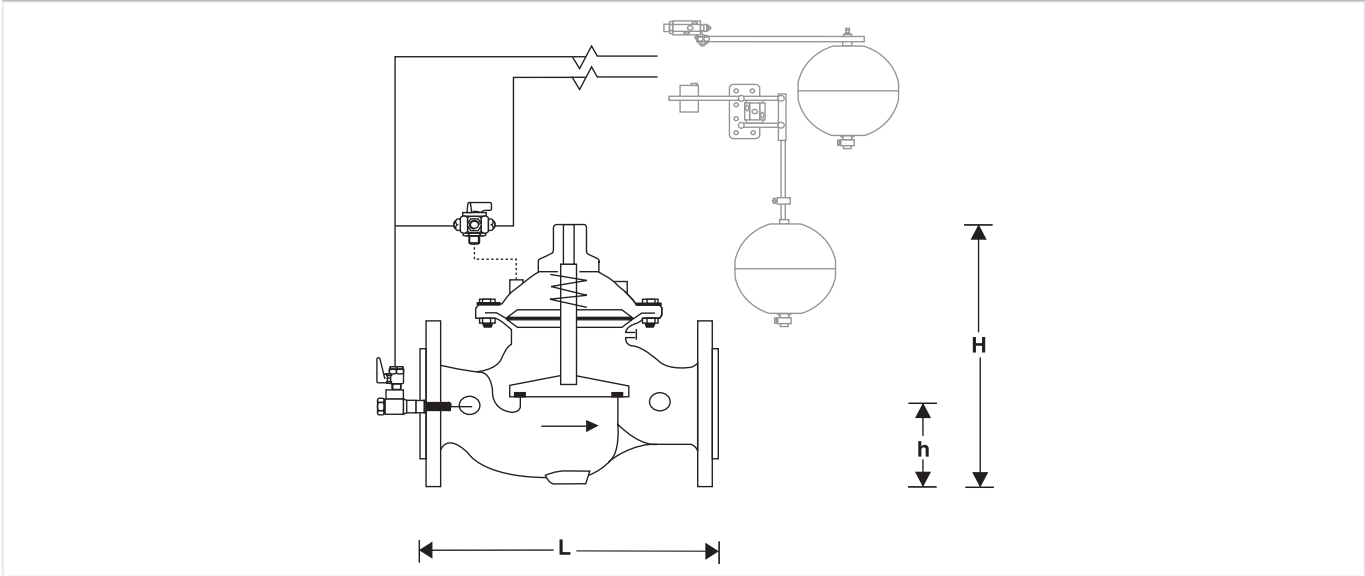

Fig. 2 Pressure drop within the valve in dependency of the flow rate and the used connection size

DIMENSIONS

Overview



Parameter		Values											
Connection sizes:	DN	50	65	80	100	150	200	250	300	350	400	450	
Weight with pilot valve:	kg	14.0	15.0	24.0	39.0	82.0	159.0	247.0	407.0	512.0	824.0	947.0	
Weight without pilot valve:	kg	12.0	13.0	22.0	37.0	80.0	157.0	245.0	405.0	510.0	822.0	945.0	
Dimensions:	L	230	292	310	350	480	600	730	850	980	1100	1200	
	H	270	280	330	350	480	570	730	870	910	1150	1170	
	h	83	93	100	110	143	173	205	230	260	290	310	

Note: All dimensions in mm unless stated otherwise.

ORDERING INFORMATION

The following tables contain all the information you need to make an order of an item of your choice. When ordering, please always state the type, the ordering or the part number.

Options

The valve is available in the following sizes: DN50, DN65, DN80, DN100, DN150, DN200, DN250, DN300, DN350, DN400 and DN450.

- standard



		FV300-...A
Connection type:	Flange PN16, ISO 7005-2, EN 1092-2	•

Note: ... = space holder for connection size

Note: Ordering number example for DN50 and type A valve: FV300-50A

Note: Please order pilot float valves separately

Accessories

	Description	Dimension	Part No.
	70-550 Pilot float valve Level switching differential 5 - 40 cm		70-550
	70-610 Pilot float valve Level switching differential 5 - 40 cm		70-610
	EXF125-A Extension flange DN125 Adapter flanges DN100 to DN125 Ductile iron, PN16 acc. ISO 7005-2 and EN 1092-2. Overall length with adapter flanges (without bolts) DN125 L=416mm, DVGW approved, including bolts, nuts and the seal disc.		EXF125-A

Spare Parts

Filling valve FV300, from 2002 onwards

Overview	Description	Dimension	Part No.
	1 Set of seals		
		DN50	0903750
		DN65	0903751
		DN80	0903752
		DN100	0903753
		DN150	0903754
		DN200	0903755
		DN250	0903756
		DN300	0903757
		DN350	0903758
	DN400	0903759	
	DN450	0903760	

For more information

homecomfort.resideo.com/europe



Ademco 1 GmbH
 Hardhofweg
 74821 MOSBACH
 GERMANY
 Phone: +49 6261 810
 Fax: +49 6261 81309

Manufactured for and on behalf of the
 Pittway Sàrl, La Pièce 4, 1180 Rolle, Switzerland
 by its Authorised Representative Ademco 1 GmbH
 ENOH-1328GE23 R0319
 Subject to change
 © 2019 Resideo Technologies, Inc.
 The Honeywell Home trademark is used under
 license from Honeywell International Inc.

