



WE TAKE BUILDING
AUTOMATION PERSONALLY



MANUAL RCF



 **REGIN**
THE CHALLENGER

DISCLAIMER

The information in this manual has been carefully checked and is believed to be correct. Regin, however, makes no warranties in regard to the contents of this manual. Users are requested to report errors, discrepancies or ambiguities to Regin, so that corrections may be made in future editions. The information in this document is subject to change without prior notification.

The software described in this document is supplied under licence by Regin and may be used or copied only in accordance with the terms of the licence. No part of this document may be reproduced or transmitted in any form or fashion, electronically or mechanically, without the express, written permission of Regin.

COPYRIGHT

© AB Regin. All rights reserved.

TRADEMARKS

EXOdesigner, EXOreal, EXOrealC, EXOline, EXO4, EXO4 Web Server, Regio and Regio tool[®] are registered trademarks of AB Regin.

Windows, Windows 2000, Windows XP, Windows Vista, Windows 7, Windows 8, Windows 8.1, Windows 10, Windows Server 2003, Windows Server 2012 are registered trademarks of Microsoft Corporation.

Some product names mentioned in this document are used for identification purposes only and may be the registered trademarks of their respective companies.

May 2016

Latest revision: 3.1

Manual for products with software revision 1.4-1-00 or later

Functions described in this manual are handled through Regio tool[®] version 1.5-1-01.

Table of contents

CHAPTER 1 ABOUT THIS MANUAL	5
Terms.....	5
Additional information	5
CHAPTER 2 INTRODUCTION TO RCF	6
RCF FAN COIL CONTROLLERS	6
RCF WITH COMMUNICATION.....	6
CHAPTER 3 MODELS	8
Design.....	9
CHAPTER 4 TECHNICAL DATA	10
COMMUNICATION	10
Accessories for RCF.....	11
CHAPTER 5 PREPARATIONS FOR INSTALLATION	12
USING LABELS.....	12
CONFIGURATION.....	13
CHAPTER 6 INSTALLATION	14
MOUNTING	14
COMMUNICATION, WIRING.....	14
Bottom plate connections	15
Wiring for models RCF(M)-230(C)TD.....	16
Wiring of various actuators.....	17
Wiring for model RCF-230CTD-EC	18
Wiring for models RCF-230(C)AD	20
Wiring for modelsRCF(M)-230(C)D.....	21
CHAPTER 7 COMMISSIONING	23
Troubleshooting	23
CHAPTER 8 CONTROL PRINCIPLES	24
RCF-230(C)TD, RCF-230CTD-EC, RCF-230(C)AD, RCFM-230TD	24
RCF-230(C)D, RCFM-230D	25
CHAPTER 9 OPERATING MODES	28
DIFFERENT OPERATING MODES	28
OCCUPANCY CONTROL	28
CHAPTER 10 BUTTON MANAGEMENT	29
CHAPTER 11 TYPES OF ACTUATORS	31
CHAPTER 12 FAN CONTROL	32
CHAPTER 13 CHANGE-OVER	34
CHAPTER 14 DISPLAY HANDLING	35
DISPLAY INDICATIONS.....	35
THE PARAMETER MENU	35
CHAPTER 15 MEMORY FUNCTIONS DURING POWER FAILURE	40
CHAPTER 16 MODBUS SIGNAL TYPES	41
CHAPTER 17 MODBUS SIGNALS	43
DISCRETE INPUTS	43

COIL STATUS REGISTER.....	44
INPUT REGISTER	45
HOLDING REGISTER.....	46
CHAPTER 18 BACNET SIGNAL TYPES.....	51
CHAPTER 19 BACNET SIGNALS	52
ANALOGUE INPUTS	52
ANALOGUE VALUES.....	52
BINARY INPUTS	53
BINARY VALUES.....	54
LOOP	54
MULTISTATE INPUTS	55
MULTISTATE VALUES.....	55
DEVICE.....	56

Chapter 1 About this manual

This manual describes the controllers in the RCF product range.

Terms

Term used in this manual:

FS Factory setting

Additional information

Additional information concerning RCF can be found in:

- *Manual Regio tool*[®] – Describes how to configure the controllers
- *Regio in EXO Projects* – Information on how the RCF can be used in the EXO system. RCF may be used in the same way as Regio Midi in the EXO system.

The information is available for download from Regin's website, www.regincontrols.com.

Chapter 2 Introduction to RCF

RCF fan coil controllers

RCF is an extensive range of fan coil controllers for control of heating, cooling and fan control. RCF enables you to create anything from stand-alone systems for managing the functions in a single room to large, integrated SCADA systems.

Models of RCF that feature the letter “C” in their designation (e.g. RCF-230CTD) offer built-in communication. Controllers featuring communication can be connected to bus lines, such as Modbus, Regin’s bus system EXOline or BACnet, in order to communicate with a central SCADA system via RS485.

Applications

The RCF line of controllers offer appealing design and functionality. They are suitable in buildings where a high level of comfort and low energy consumption are desired, such as offices, schools, shopping centres, airports, hotels and hospitals.

Models are available for control of analogue, thermal, and three-position actuators, as well as models offering thermostat functions. There are models for control of either an EC fan or of a three-step fan-coil unit.

Mounting

The modular design with a separate bottom plate for wiring makes all controllers in the RCF line easy to install and commission. Mounting takes place directly on the wall or on a device box.

RCF with communication

Communication

The controllers can be connected to a central SCADA system via RS485 (EXOline, Modbus or BACnet) and configured for a specific application using the configuration software Regio tool[®], downloadable free of charge from the Regin website www.regincontrols.com. Additional information can be found in the Regio tool[®] manual. RCF-230CD, RCF-230CAD and RCF-230CTD are BTL listed from software version 1.2-1-00 (BACnet stack 3.0.4).

Control

The controllers can be configured for the following control modes/control sequences:

- Heating or cooling via change-over function
- Change-over/Heating (Only RCF-230(C)TD and RCF-230CTD-EC, which is configured for electric heater)
- Heating/Cooling

Application examples

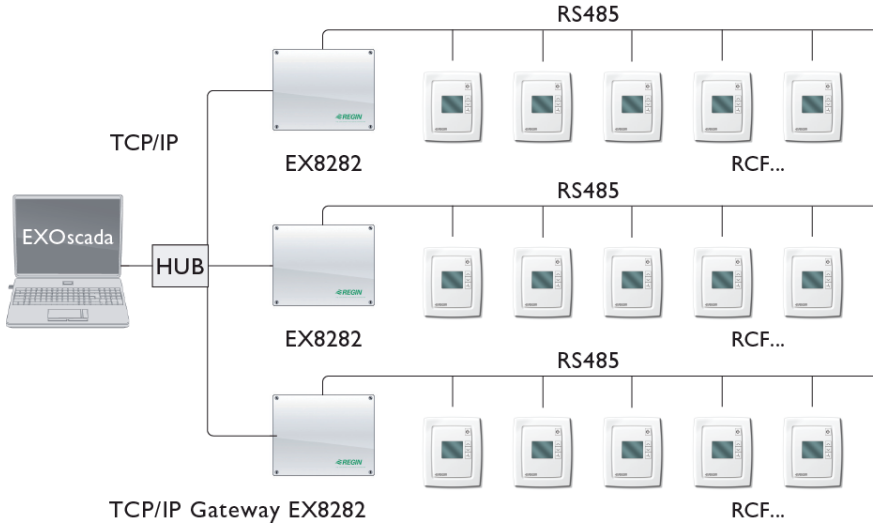
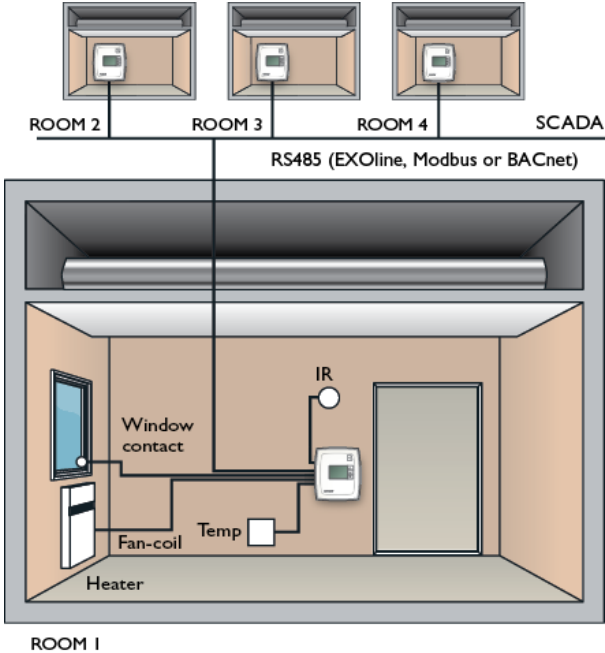

Chapter 3 Models

The RCF line consists of 9 different models of room controllers.

Models	Manual Change-over	2-pipe	4-pipe	Electric heater	3-position control	Thermal actuators	On/Off control	0-10 V DC control	Communication*
RCF-230(C)TD		•	•	•	•	•			(•)
RCFM-230TD	•	•			•	•			
RCF-230(C)AD		•	•					Valve	(•)
RCF-230(C)D		•	•				•		(•)
RCFM-230D	•	•					•		
RCF-230CTD-EC		•	•	•	•	•		Fan	•

* Applies only to models with a "C" in the second part of their name

Design



Figure 1. RCF-230X



Figure 2. RCFM-230X

Chapter 4 Technical data

Supply voltage	230 V AC \pm 10 %, 50...60 Hz
Power consumption	< 3 W
Outputs, relays for fan control	230 V AC, 3 A fan-coil (NA for RCF230-CTD-EC)
Actuator, Triac.....	230 V AC, max. 300 mA (NA for RCF230-(C)AD)
Basic setpoint	5...50°C (0...100°C with Regio tool [®])
Hysteresis	\pm 0.5 K (adjustable)
P-band.....	10°C (NA for RCF/M-230D)
I-time	300 s (NA for RCF/M-230D)
Analogue input	One PT1000
Digital input.....	One closing potential-free contact
Universal input	One PT1000 or closing potential-free contact (NA for RCFM-230xx)
Mounting	Wall
Protection class.....	IP20

Communication

Type	RS485: EXOline or Modbus (with automatic detection/ change-over) or BACnet (without automatic change-over)
Communication speed	9600, 19200, 38400 bps (EXOline, Modbus and BACnet) or 76800 bps (BACnet only)
Functions as	
Modbus.....	RTU slave
BACnet.....	B-ASC, MS/TP
Modbus	Odd or even (FS) parity and one stop bit or no parity and two stop bits

Memory

Non-volatile (EEPROM) All settings and configurations are saved
See also chapter named *Memory functions during power failure*.

Built-in temperature sensor

Type	NTC, linearised, 10 kOhm
Measuring range	0...50°C
Accuracy of measurement	\pm 1.5°C at 15...30°C

Built-in display

Display type..... Backlit, LCD

CE

This product conforms to the EMC and LVD requirements in the European harmonised standards EN 60730-1:2000 and EN 60730-2-9:2002. It carries the CE mark.

ROHS

This product conforms to the Directive 2011/65/EU of the European Parliament and of the Council.

Inputs

AI.....	External PT1000 sensor instead of the internal NTC
UI.....	Digital/Analogue input; potential-free window contact,Change-over input; potential-free switch (configurable for NO/NC) <i>or</i> PT1000
DI.....	Digital input; potential-free window contact or occupancy contact,configurable for NO/NC.

Outputs

DO1	Fan-coil output 1 for fan control, relay, 230 V AC, 3 A
DO2	Fan-coil output 2 for fan control, relay, 230 V AC, 3 A
DO3	Fan-coil output 3 for fan control, relay, 230 V AC, 3 A
DO4	Digital output 4 for heating/cooling, 230 V AC, max. 300 mA (3A initially).
DO5	Digital output 5 for heating/cooling, 230 V AC, max. 300 mA (3A initially).
AO1, AO2	Analogue outputs, 0...10 V DC, max. 1 mA, short-circuit proof, Adjustable to 2...10 V, 10...0 V, 10...2 V

For more information on inputs and outputs, see chapter *Wiring*.

Accessories for RCF

External temperature sensor	TG-R5/PT1000, TG-UH/PT1000, TG-A1/PT1000
Presence detector	IR24-P
Change-over	TG-A1/PT1000

The accessories are available from Regin. For more detailed information concerning these accessories, see the individual product sheet and instruction for each product, available via www.regincontrols.com.

Chapter 5 Preparations for installation

Using labels

A series of labels are located on the back of the electronics cassette, which simplify extensive installations of RCF controllers. By using these labels to convey information to the individual responsible for the physical installation, it is possible to save much time and to minimise errors during wiring.

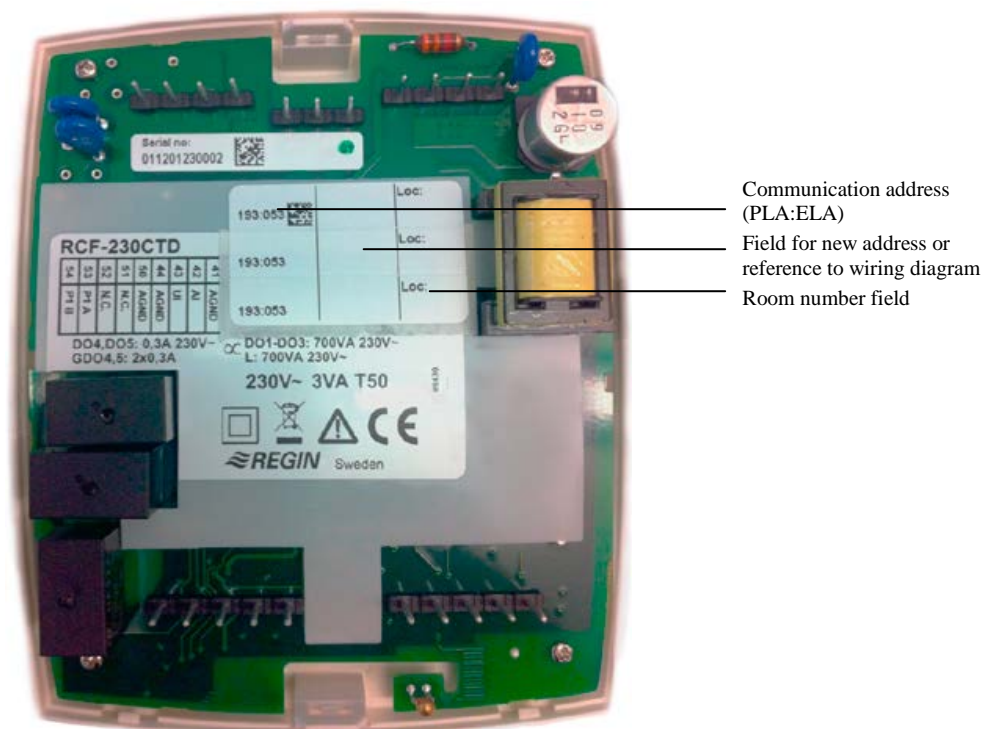

Figure 3. Label on the back of the controller

The three-piece label can be divided and its parts attached to the building drawings and the bottom part of the controller. The label contains information regarding communication address etc., together with a field for notes where a reference number for the wiring diagram can be entered.

Depending on the communication protocol used, the address on the label can mean different things.

Example 1

If the label address is 191:183, the following addresses are used for the different communication protocols:

EXOline: PLA=191, ELA=183.

Modbus: Address=183.

BACnet: Device ID=191183 (the 4 low digits=1183, the 3 high digits=19), MS/TP MAC address=83.

Example 2

If the label address is 10:001, the following addresses are used for the different communication protocols:

EXOline: PLA=10, ELA=1.

Modbus: Address=1.

BACnet: Device ID=10001 (the 4 low digits=1, the 3 high digits=1), MS/TP MAC address=1.

Configuration

Regio tool[®] is used in order to configure the electronic unit. Password for the different log on levels in Regio tool[®] is 1111 (log on as an administrator) and 3333 (log on as an operator). This will work for models with integrated communication. In all other models, the device is configured via the display.

The computer running Regio tool[®] is connected to the back of the device by way of a converter (USB to RS485). The converter is connected to terminals 53 and 54.

If the electronic unit needs to be configured, it may be advantageous to do so before it is sent to the building in which it is to be installed. For more information on configuring, see the chapter *Configuration*.

The bottom plate containing information on placement and wiring can be sent separately to the building for electrical installation.

Chapter 6 Installation

Mounting

Mount the controller in a location that has a temperature representative for the room. A suitable location is approx. 1.6 m above floor level in a place with unobstructed air circulation.

Depress the locking tab in the top edge of the cover by using a screwdriver. Gently twist the screwdriver until the bottom plate and the electronic unit separate somewhat (see figure 3, below). Then use the gap visible at the edge of the bottom plate to open the top half completely (see figure 4). Do the same thing for the bottom half of the device.



Figure 3



Figure 4

Lift the electronics unit up from the bottom plate. The bottom plate with terminals has a number of fixing hole patterns. Select suitable holes and screw the bottom plate onto the wall or connection box, so that the arrows on the bottom plate point upwards.

NOTE: Do not fasten the screws too tightly!

Communication, wiring

The communication cable must be a screened, twisted pair cable. If the length of the loop exceeds 300 m, a repeater is required. See figure below:

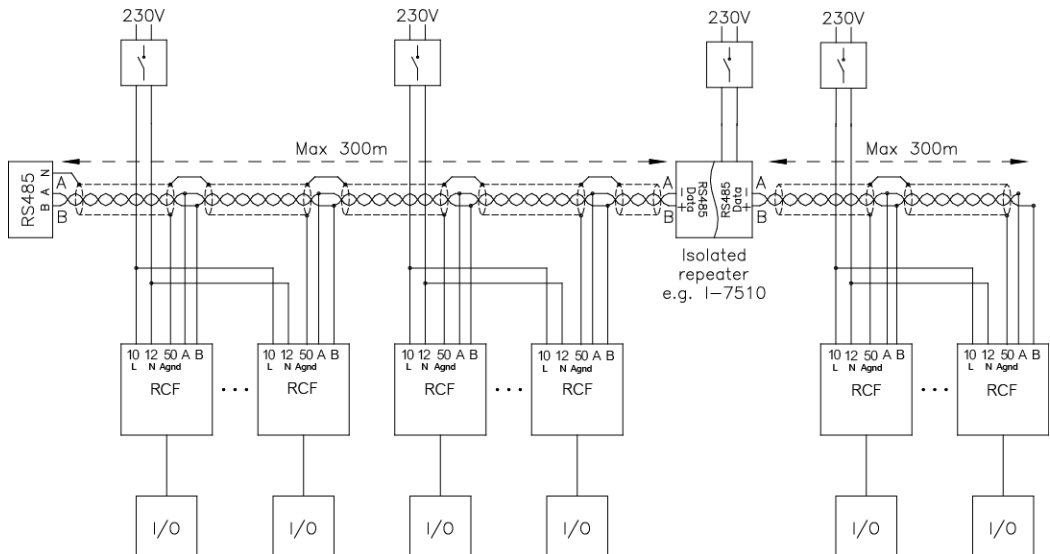

Figure 5. Wiring

Bottom plate connections

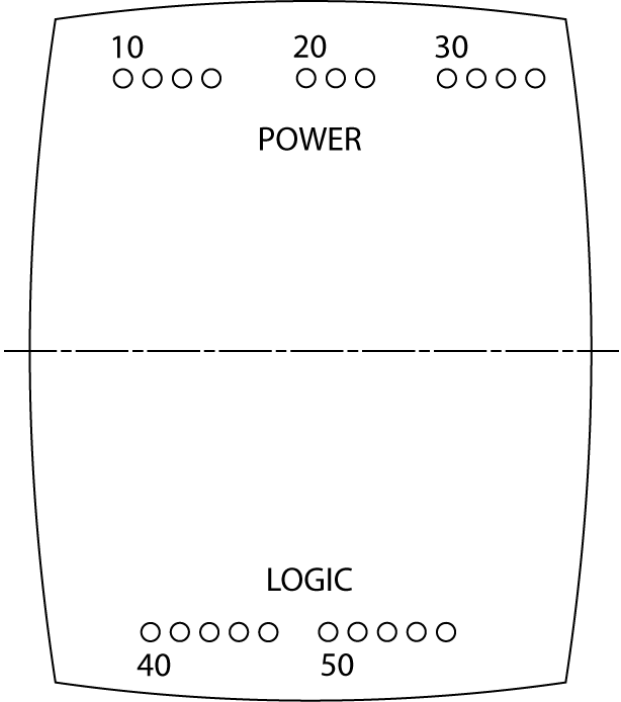
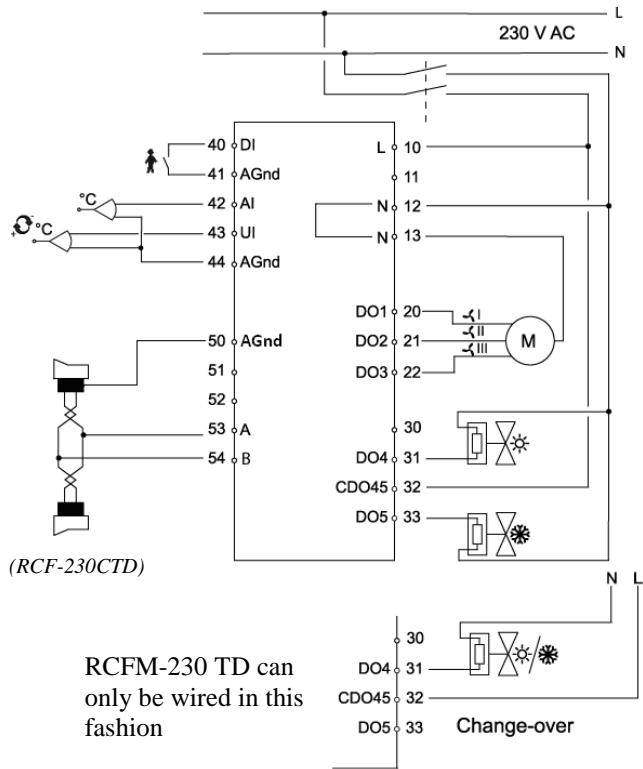

Figure 6. Bottom plate connections

Wiring for models RCF(M)-230(C)TD

Wiring of thermal actuator



Wiring of electric heater with solid state-relay

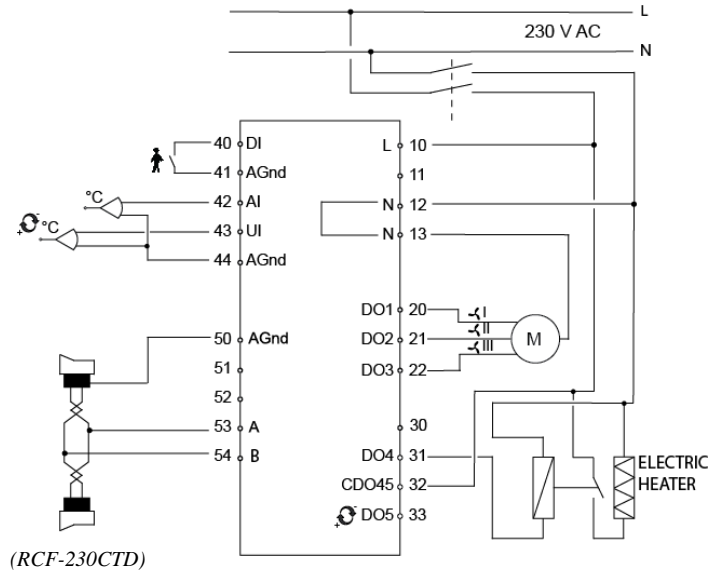

Wiring of 3-position actuator

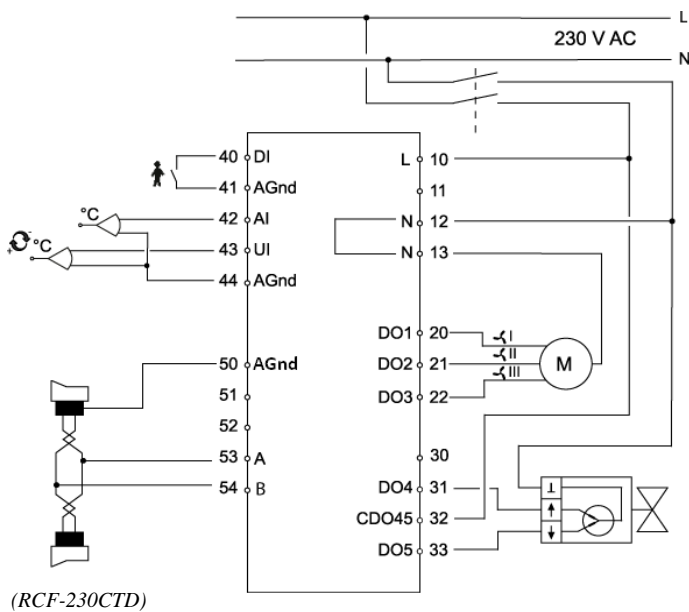

Wiring of electric heater with PULSER-ADD

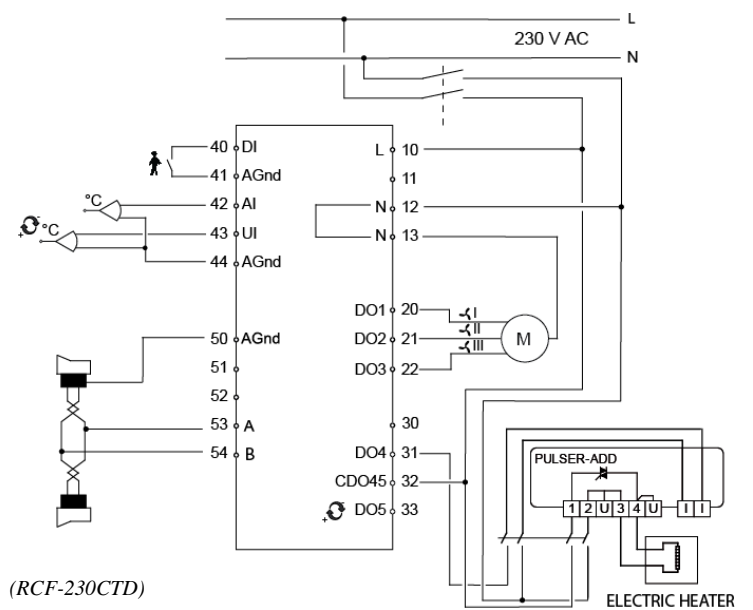

Wiring of various actuators

When wiring thermal actuators, DO4 is used for heating and DO5 for cooling actuators. If the change-over function is used together with a 2-pipe installation, the actuator should be connected to DO4 if an electric heater is not used. If an electric heater is used, the change-over function is instead located on DO5. When wiring 3-position actuators, DO4 is used for the increase signal and DO5 for the decrease signal, including when the change-over function is used.

Terminal	Designation	Description	Function
10	L	230 V AC Line	Supply voltage
11	NC	Not connected	
12	N	230 V AC Neutral	Power supply (internally connected to terminal 13)
13	N	Fan-coil common / 230 V AC Neutral	Common fan-coil connector (internally connected to terminal 12)
20	DO1	Fan-coil output 1 for fan control	Relay, 230 V AC, 3 A
21	DO2	Fan-coil output 2 for fan control	Relay, 230 V AC, 3 A
22	DO3	Fan-coil output 3 for fan control	Relay, 230 V AC, 3 A
30	NC	Not connected	
31	DO4	Digital output 4 for heating/cooling or opening with 3-point actuator	Digital output, 230 V AC, max 300 mA (3 A initially)
32	CDO45	Common DO4 & 5	Common connection for digital outputs 4 and 5
33	DO5	Digital output 5 for cooling or closing with 3-point actuator Heating/cooling signal when electric heater is configured.	Digital output, 230 V AC, max 300 mA (3 A initially)
40	DI	Digital input	Floating (potential-free) window contact or occupancy contact. Configurable for NO/NC.
41	AGnd	Analogue ground	
42	AI	Analogue input	For external room sensors or supply air temperature limitation sensor, PT1000. Measuring range 0...50°C. The sensor is connected between terminals 42 and 44, AGnd.
43	UI	Universal input	Potential-free window contact or dito change-over input (configurable for NO/NC) or analogue PT1000 sensor.
44	AGnd	Analogue ground	
50	AGnd	Analogue ground	
51	AO1	Not connected	
52	NC	Not connected	
53	A	RS485 communication A	RCF-230CTD
54	B	RS485 communication B	RCF-230CTD

Wiring for model RCF-230CTD-EC

Wiring diagram

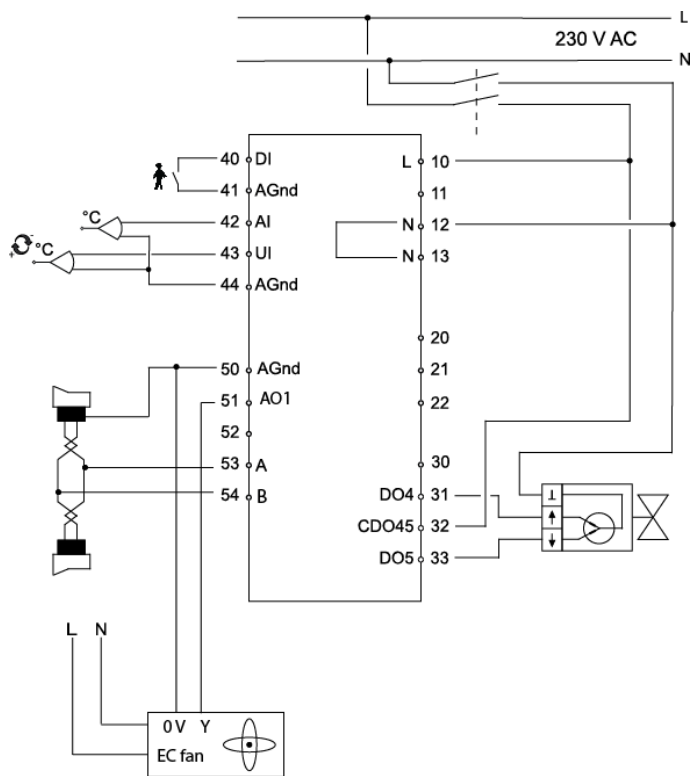

Wiring for change-over

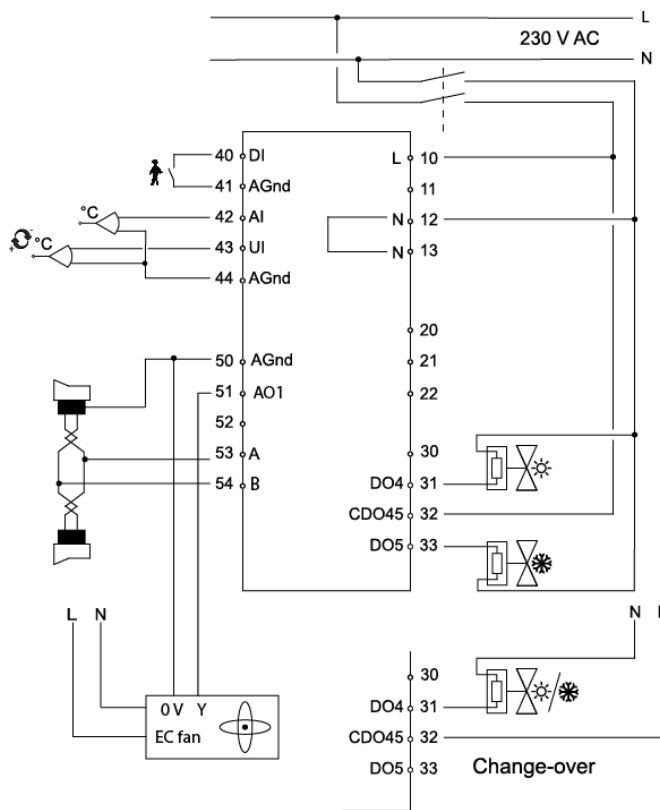

Wiring of electric heater

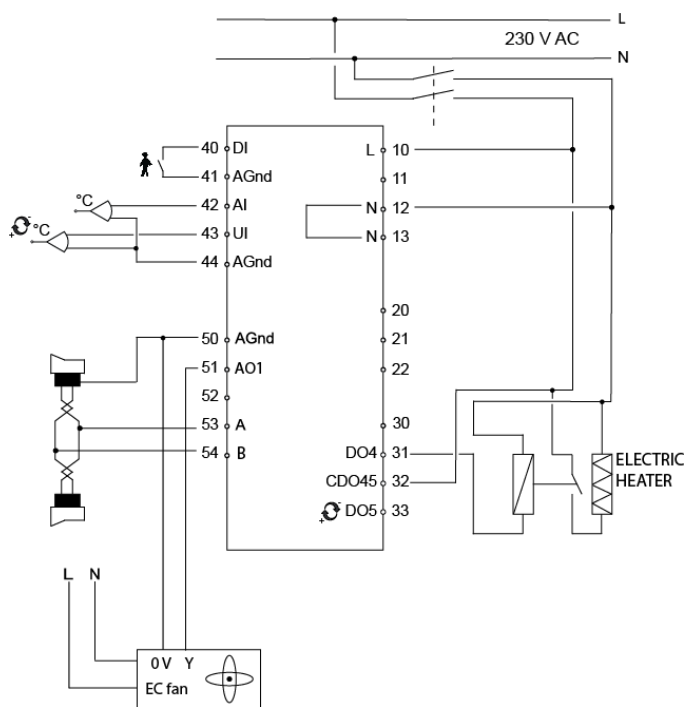

Wiring of electric heater and PULSER-ADD

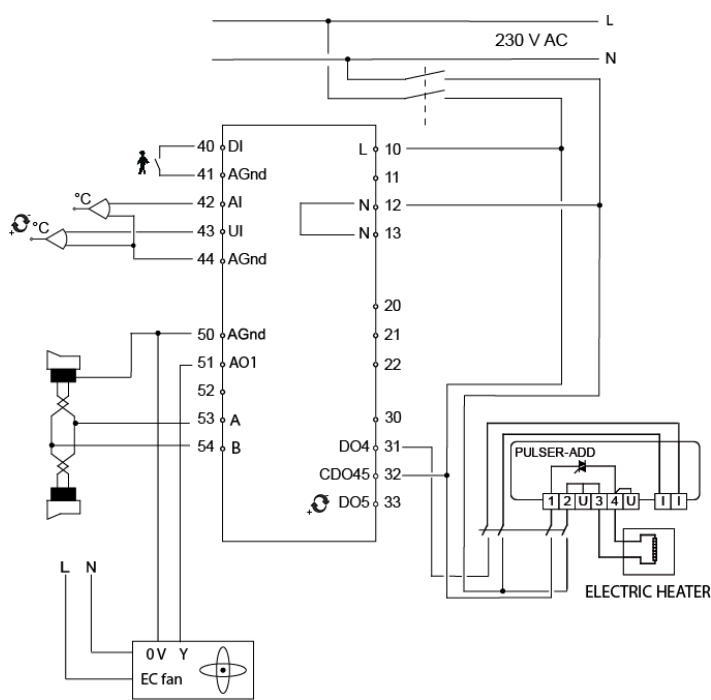

Terminal	Designation	Description	Function
10	L	230 V AC Line	Supply voltage
11	NC	Not connected	
12	N	230 V AC Neutral	Power supply (internally connected to terminal 13)
13	N	Fan-coil common / 230 V AC Neutral	Common fan-coil connector (internally connected to terminal 12)
30		Not connected	
31	DO4	Digital output 4 for heating/cooling or opening with 3-point actuator	Digital output, 230 V AC, max 300 mA (3 A initially)
32	CDO45	Common DO4 & 5	Common connection for digital outputs 4 and 5
33	DO5	Digital output 5 for cooling or closing with 3-point actuator. Heating/cooling signal when electric heater is configured.	Digital output, 230 V AC, max 300 mA (3 A initially)
40	DI	Digital input	Floating (potential-free) window contact or occupancy contact. Configurable for NO/NC.
41	AGnd	Analogue ground	
42	AI	Analogue input	For external room sensors or supply air temperature limitation sensor, PT1000. Measuring range 0...50°C. The sensor is connected between terminals 42 and 44, AGnd.
43	UI	Universal input	Potential-free window contact or dito change-over input (configurable for NO/NC) or analogue PT1000 sensor.
44	AGnd	Analogue ground	
50	AGnd	Analogue ground	
51	AO1	Wiring of control signal for EC fan	
52	NC	Not connected	
53	A	RS485 communication A	
54	B	RS485 communication B	

Wiring for models RCF-230(C)AD

Wiring of 0...10 V actuator

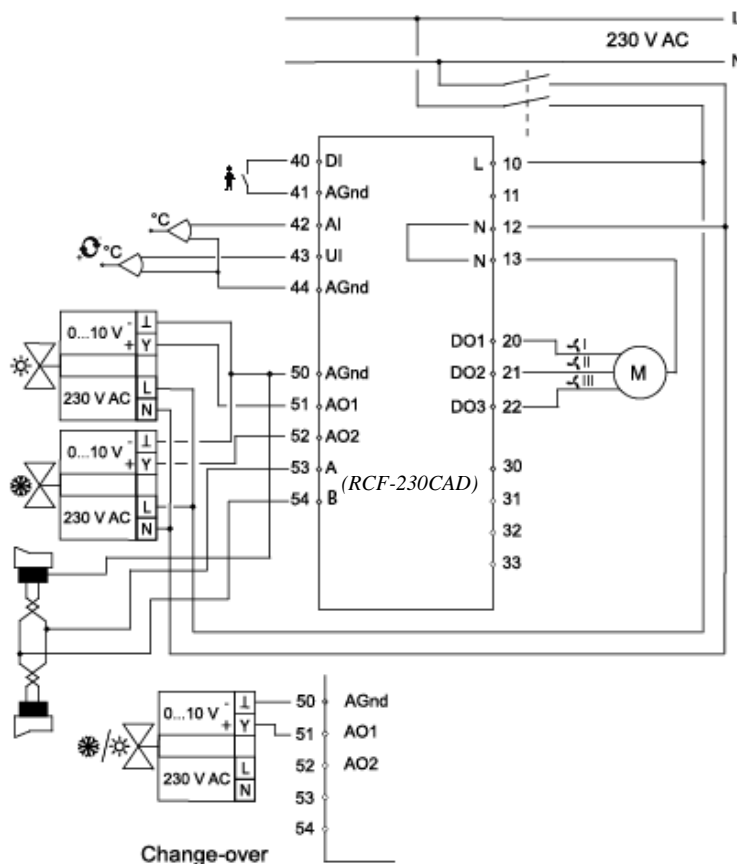

Terminal	Designation	Description	Function
10	L	230 V AC Line	Supply voltage
11	NC	Not connected	
12	N	230 V AC Neutral	Power supply (internally connected to terminal 13)
13	N	Fan-coil common / 230 V AC Neutral	Common fan-coil connector (internally connected to terminal 12)
20	DO1	Fan-coil output 1 for fan control	Relay, 230 V AC, 3 A
21	DO2	Fan-coil output 2 for fan control	Relay, 230 V AC, 3 A
22	DO3	Fan-coil output 3 for fan control	Relay, 230 V AC, 3 A
30-33	NC	Not connected	
40	DI	Digital input	Floating (potential-free) window contact or occupancy contact. Configurable for NO/NC.
41	AGnd	Analogue ground	

Terminal	Designation	Description	Function
42	AI	Analogue input	For external room sensors or supply air temperature limitation sensor, PT1000. Measuring range 0...50°C. The sensor is connected between terminals 42 and 44, AGnd.
43	UI	Universal input	Potential-free window contact or dito change-over input (configurable for NO/NC) or analogue PT1000 sensor.
44	AGnd	Analogue ground	
50	AGnd	Analogue ground	
51	AO1	Analogue output 1	
52	AO2	Analogue output 2	
53	A	RS485 communication A	RCF-230CAD
54	B	RS485 communication B	RCF-230CAD

Wiring for models RCF(M)-230(C)D

Wiring of on/off actuator

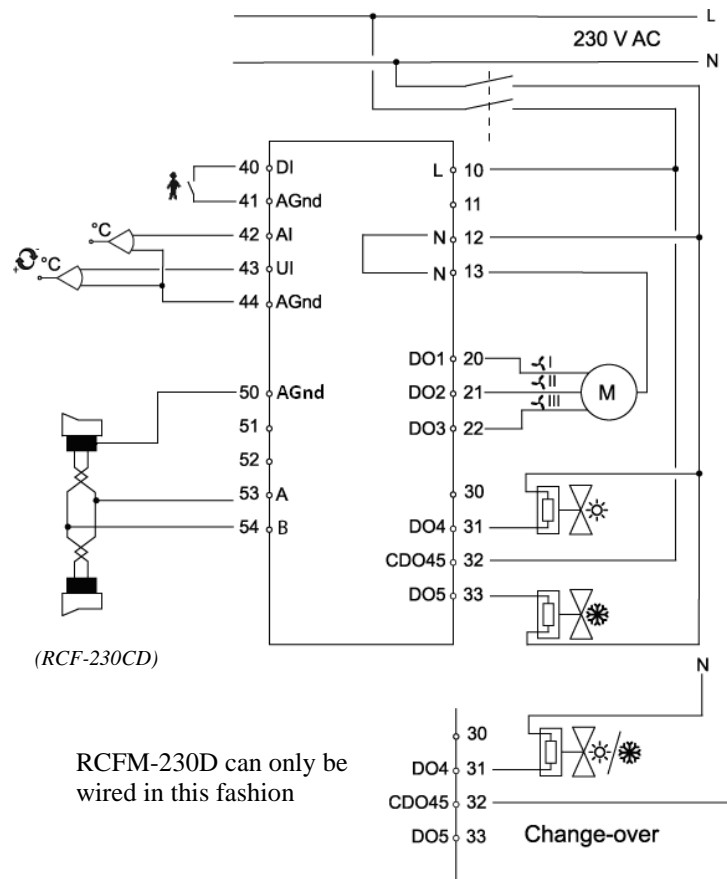

Terminal	Designation	Description	Function
10	L	230 V AC Line	Supply voltage
11	NC	Not connected	
12	N	230 V AC Neutral	Power supply (internally connected to terminal 13)
13	N	Fan-coil common / 230 V AC Neutral	Common fan-coil connector (internally connected to terminal 12)
20	DO1	Fan-coil output 1 for fan control	Relay, 230 V AC, 3 A
21	DO2	Fan-coil output 2 for fan control	Relay, 230 V AC, 3 A
22	DO3	Fan-coil output 3 for fan control	Relay, 230 V AC, 3 A
30	NC	Not connected	
31	DO4	Digital output 4 for heating/cooling signal	Digital output, 230 V AC, max 300 mA (3 A initially)
32	CDO45	Common DO4 & 5	Common connection for digital outputs 4 and 5
33	DO5	Digital output 5 for heating/cooling signal	Digital output, 230 V AC, max 300 mA (3 A initially)
40	DI	Digital input	Floating (potential-free) window contact or occupancy contact. Configurable for NO/NC.
41	AGnd	Analogue ground	
42	AI	Analogue input	For external room sensors or supply air temperature limitation sensor, PT1000. Measuring range 0...50°C. The sensor is connected between terminals 42 and 44, AGnd.
43	UI	Universal input	Potential-free window contact or dito change-over input (configurable for NO/NC) or analogue PT1000 sensor.
44	AGnd	Analogue ground	
50	AGnd	Analogue ground	
51	NC	Not connected	
52	NC	Not connected	
53	A	RS485 communication A	RCF-230CAD
54	B	RS485 communication B	RCF-230CAD

Chapter 7 Commissioning

For models with communication, it is easiest to set parameters by using Regio tool[®]

If the measured room temperature is to be compensated for, this should be performed only under stable conditions.

Troubleshooting

The Manual/Auto function in Regio tool[®] enables testing various outputs. The output itself is not affected directly, but rather the software object that controls the output. This means that the built-in safety functions cannot be deactivated.

The controllers have different types of indications which can be used to support troubleshooting. See section *Indications*.

Chapter 8 Control principles

RCF-230(C)TD, RCF-230CTD-EC, RCF-230(C)AD, RCFM-230TD

Control principle for cooling function, 2-pipe installations

During control of cooling, the output starts to increase when the temperature rises above the setpoint value.

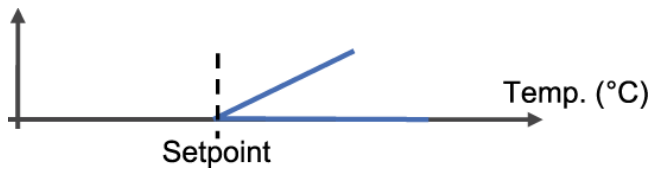

Control principle for heating function, 2-pipe installations

During control of heating, the output starts to increase when the temperature falls below the setpoint value.

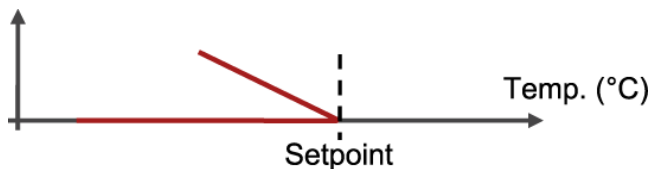

Control principle in 4-pipe installations

At Comfort mode, neither heating nor cooling is used in order to minimise energy consumption when the temperature is in the deadband (DB). The heating output is activated when the temperature falls below the set value for the deadband. The cooling output is activated when the temperature exceeds the set value for the deadband. The deadband is divided into two equal parts with one part below and one part above the setpoint. See the figure below. The factory setting for the deadband is 2 K.

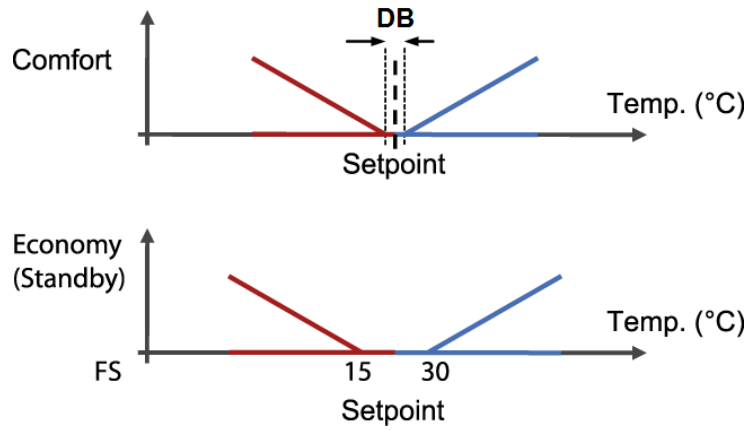

The above schematic drawings of the control principle show the corresponding requirement of the controller function. This requirement is recalculated by the controller to a value for the actuator output, depending on the selected output function.

RCF-230(C)D, RCFM-230D

Control principle at cooling function

During control of cooling, the output is activated when the temperature rises above the setpoint by the set hysteresis (ΔT). The output closes when the setpoint value is reached.

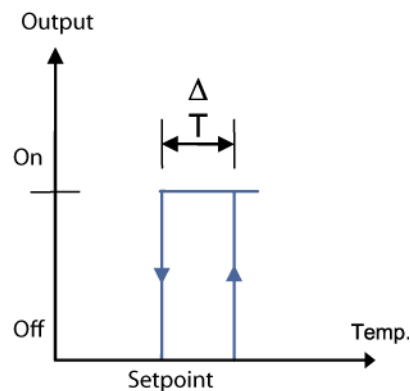

Control principle at heating function

During control of heating, the output is activated when the temperature falls below the setpoint by the set hysteresis. The output closes when the setpoint value is reached.

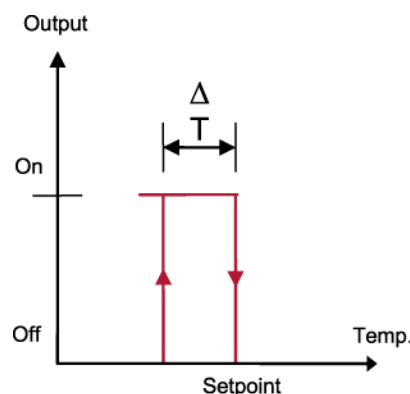

Control principle at Heating/Cooling with electric heater and change-over on DO5

RCF-230CTD(-EC) has a function for pulse/pause control of electric heaters. This function is similar to the control of a thermal actuator.

When using an electric heater, the fan will run for an additional 2 minutes after the heater has been shut down in order to cool it off. When an electric heater is used, an external unit (such as PULSER-ADD or a solid state relay) must be connected between RCF-230CTD(-EC) and the heater. NOTE: RCF-230CTD(-EC) has no indication capable of showing if the fan breaks or if the heater should overheat. This requires all safety connections to be made externally. An overheating protection or similar can be used to cut the supply voltage.

When using an electric heater while change-over is set to heating, RCF-230CTD(-EC) will work using the sequence heating/heating, where DO5 will be activated first. If change-over is set to cooling, DO5 will be the cooling output and DO4 will supply support heating if needed.

If no change-over-sensor is used, cooling mode is activated using parameter 2 in the menu or via SCADA communication.

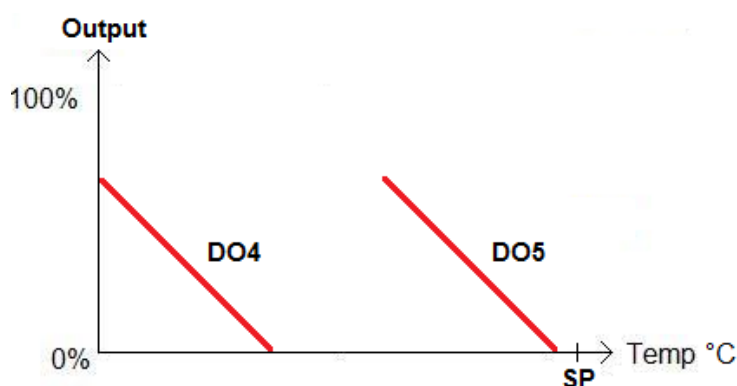

The picture describes the DO4 and DO5 outputs as a function of the temperature when the controller is set to Heating/Heating.

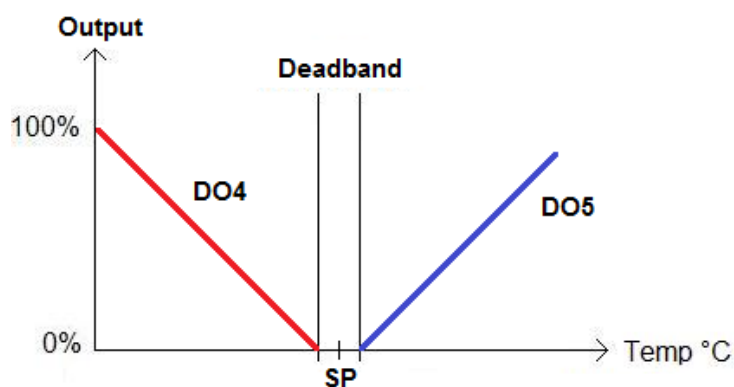

The picture describes the DO4 and DO5 outputs as a function of the temperature when change-over is set to cooling control.

Min and max supply air limitation

Analogue input 1 (AI1) can be configured for use with a supply air temperature limitation sensor. The controller will then automatically switch to cascade control. There are four values for min and max limitation. The settable range is 10°C...50°C. The default setting is:

Control mode	Min limitation	Max limitation
Heating	24°C	35°C
Cooling	12°C	24°C

A room controller will then work together with a supply air temperature controller using cascade control, resulting in a calculated supply air temperature maintaining the room temperature setpoint.

The cascade factor consists of the supply air controller being faster than the room controller. The cascade factor in RCF acts as a divisor which affects both the P-band and I-time.

Example: If the cascade factor is 3 and the room controller has a P-band of 10°C and an I-time of 300 s, the supply air controller will receive a P-band of 3°C and an I-time of 100 s. The supply air controller will therefore be 3 times as fast as the room controller.

Chapter 9 Operating modes

Different operating modes

There are four different operating modes. Switching between these modes is performed locally. In controllers with communication, the operating mode can also be changed through the main SCADA system.

Comfort

 is shown in the display. A presence detector can be connected to DI in order to choose between Comfort and Economy. Switching between Comfort/Economy and Off can also be performed via the occupancy button. Comfort/Economy is selected via the parameter list.

Economy (Standby)

“Standby” is shown in the display. Heating and cooling have freely adjustable setpoints. Factory settings: heating = 15°C, cooling = 30°C,

Off

The controller neither heats nor cools and the fan is at a standstill, assuming mould protection has not been selected in which case the fan is still running.

Windows

 is shown in the display. The controller will cease all heating and cooling control and the fan will stop unless mould protection or cooling of an electric heater has been selected. The potential-free window contact is connected to DI or UI1 and must be configured in the parameter list or by using Regio tool[®].

Occupancy control

Parameter 3 decides whether DI is the input for a window contact or a presence detector. A presence detector can be connected to DI in order to choose between Comfort and Economy mode.

Chapter 10 Button management



On/Off button

By pressing the On/Off button, RCF will switch between Off mode and Comfort/Economy mode.

Setpoint buttons

The INCREASE and DECREASE buttons are used to change the setpoint displacement. The desired contents of the display can be configured via the parameter list. There are four alternatives:

1. The actual value is shown, or, when the setpoint displacement has been changed via the INCREASE and DECREASE buttons, the setpoint value is shown in the display together with the setpoint (thermometer) symbol.
2. The actual value is shown, or, when the setpoint displacement has been changed via the INCREASE and DECREASE buttons, the setpoint displacement is shown in the display together with the setpoint (thermometer) symbol.
3. The setpoint value is shown (factory setting).
4. The setpoint displacement is shown.

The basic setpoint is changeable in parameter 64 (factory setting=22°C).

Fan button

By pressing the fan button, the fan speed is set to to Low, Medium, High and Auto.

If the fan has been configured not to be affected by the controller output, the "AUTO" option will not be shown when pressing the fan button.

Configuration via the parameter list

The factory settings are changed in the parameter list shown in the display by using the buttons on the controller.

The parameter values are changed with the INCREASE and DECREASE buttons and changes confirmed with the On/Off button.

Setpoint displacement

In parameter 34 and 35 it is possible to set the maximum permitted increase as well as decrease of the setpoint displacement. The displacement is added to the basic setpoint. The maximum permitted increase is 0...13K and the maximum permitted decrease is 0...17K.

Button functionality blocking

To prevent access from unauthorized users, the RCF controllers have a built-in function for blocking the functionality of the buttons. Blocking can take place in different ways, as shown in the below tables. The Up/Down buttons will always be blocked/unblocked at the same time. If the Up/Down buttons are blocked, the parameter list can still be reached normally. Button blocking is available in all RCF models. The function is set using parameter 65.

Configuration options	Fan button / On/Off button active	Up/Down buttons active	M-button / Fan button active
0			
1	•		
2		•	
3	•	•	
4			•
5	•		•
6		•	•
7	•	•	•

Configuration options for M-models and non M-models

Configuration menu blocking

This function prevents unauthorized access to the configuration menu via the buttons on the front. When the function is activated all buttons will still work normally, but the configuration menu will no longer be accessible. In order to prevent the controller from accidentally being locked in an unconfigurable mode, this function can only be activated externally using communication (Modbus, EXOline or Regio tool[®]). The function therefore only applies to models with built-in communication.

Blocking of device during fire alarms

It is possible to completely block RCF during, for instance, fire alarms. This function can only be activated via Modbus communication (Coil status register 3) or through communications via BACnet (Binary value, 9).

If the current value has not first been set to “0”, the function will force the unit into Shutdown mode and prevent it from being activated again. This means the device cannot be started via the On/Off button for as long as this function is active.

Chapter 11 Types of actuators

RCF can be used with four types of actuators:

- Analogue 0...10 V DC actuators
- Thermal actuators
- 3-point actuators (Increase/decrease actuators)
- On/Off actuators (thermostat function)

The type of actuator is configured using Regio tool [®] or in the parameter menu of the display.

RCF-230(C)AD

For analogue actuators, the following output signal adjustments can be made::

- 0...10 V (FS)
- 2...10 V
- 10...2 V
- 10...0 V

RCF-230(C)TD

When control of a thermal actuator has been selected, it is controlled digitally through output DO... via time proportional pulses. By pulsing, the degree of opening of the actuator (and its valve) is varied. The period time (in seconds) equals the sum of output on time and output off time. The factory setting (FS) for period time is 60s. The controller varies output on time and off time proportionally, depending on the output signal requirements of the actuator.

RCF-230(C)TD

For 3-position actuators, two digital outputs (DO4/DO5) are used for control of a single actuator; one output controlling opening the actuator and another closing it. The run time (in seconds) can be configured for different actuators (FS=120 s).

Exercising

All actuators, independent of type, are exercised. This is performed by the controller at a set interval measured in hours (FS=23 hour interval). Exercising means a signal to open is sent to the actuator for as long as the actuator's configured run time. A signal to close is then sent for an equal amount of time, after which exercising is completed.

The interval between exercises is set in parameters 22 and 23. If the parameter is set to "0", the function is deactivated.

If an electric heater has been selected, no exercise will take place.

Number of parameter	Description	Factory setting
22	Time (in hours) between exercise of heating actuator	23
23	Time (in hours) between exercise of cooling actuator	23

RCF-230(C)D

For On/Off actuators, two digital outputs (DO4/DO5) are used to control two magnetic valves.

On/Off actuators

The thermostat controls heating and/or cooling in a room via on/off outputs (DO4/DO5). It has a settable hysteresis, with a factory setting of 1 K (°C). The setpoint displacement can be changed using the INCREASE (↗) and DECREASE (↘) buttons on the front.

Chapter 12 Fan control

Automatic fan speed control for RCF-230(C)TD, RCF-230CTD-EC, RCF-230(C)AD and RCFM-230TD

The current fan speed is shown in the display and can be set manually to Low, Medium or High speed. It can also be set to Auto, which means that the fan speed is controlled by the heating and/or cooling demand, depending on the configuration.

By pressing the fan button, the fan speed is set to Low → Medium → High or → Auto.

The factory setting in the Auto position is that the fan speed is controlled at both heating and cooling demand. The first step starts when the output signal from the controller internally exceeds 20 % (5% if an electric heater is used). The second step starts at 60 % and the third at 100 %. When the fan speed decreases, each fan step has a hysteresis of 5 % for changing over to the next step. For example, the fan will change from the third to the second step when the output signal falls below 95 %.

RCF-230CTD-EC

This model has a built-in function for control of an EC fan, 0...10 V, using analogue output AO1. The fan control takes place linearly in conjunction with the cooling/heating output, or together with the function otherwise selected for fan control. During manual output, control takes place in three stages, and the level of each stage is set using parameters 26, 27 and 28.

The EC fan can be min. and max. limited (FS 10 % and 100 %) using parameters 67 and 68. A stop hysteresis is also available via parameter 29 (FS 5 %).

Automatic fan speed control for RCF-230(C)D and RCFM-230D

The current fan speed is shown in the display and can be set manually to Low, Medium or High speed. It can also be set to Auto, which means that the fan speed is controlled by the heating and/or cooling demand, depending on current configuration.

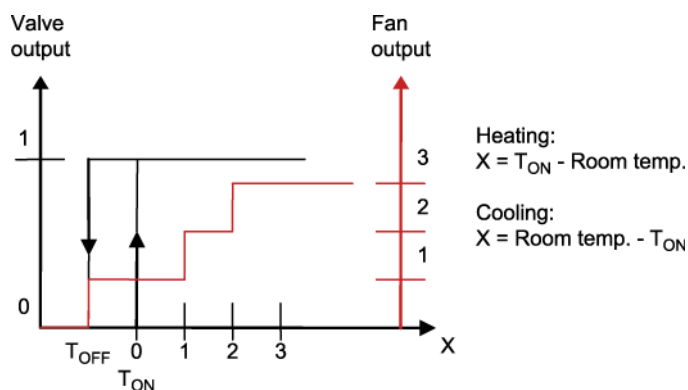

RCF (all models)

By pressing the fan button, the fan speed is set to Low → Medium → High or → Auto.

When there is no heating or cooling demand in the Auto position, the fan will run at its lowest setting. This is editable in parameter 31, enabling the fan to stop entirely when there is no heating or cooling demand. The fan is also inactive in the Off and Window modes. However, it will continue to run if mould protection has been configured. If the fan has been configured not to be affected by the controller output (parameter 25), the "Auto" option will not be shown when pressing the fan button.

Number of parameter	Description	Factory setting
25	Configuration of fan control: 0=No control, 1=The fan is controlled by heating requirement, 2=The fan is controlled by cooling requirement, 3=The fan is controlled by both heating and cooling requirement. When using an electric heater this parameter should only be set to 1 or 3, otherwise there is a risk of overheating.	3

Mould protection

When this function has been configured, the fan will always run at the lowest speed and circulate air in the room to minimise the risk of mould growth in the fan-coil unit. The function is deactivated on delivery.

Prevent manual fan control

This function prevents manual fan control in cases where the cooling/heating control signal should have no influence on the fan. Observe that, if the function is active when fan control is simultaneously set to follow neither the cooling nor the heating signal, it will not be possible to control the fan using the fan button. The function is activated/deactivated in parameter 66 and the fan, if active, will follow the behaviour according to the schematic for parameter 25, below.

The function is structured as detailed below:

Setting of parameter 25	Manual fan control available?	
	If heating signal	If cooling signal
0 = The fan is controlled neither by cooling or heating demand	No	No
1 = The fan is controlled by heating demand	Yes	No
2 = The fan is controlled by cooling demand	No	Yes
3 = The fan is controlled by both cooling and heating demand	Yes	Yes

Fan kickstart

When using today's energy-saving fans, there is always a risk the fan will not start due to the low control voltage preventing the fan from exceeding its starting torque. The fan will then remain at a standstill while power still flows through it, which may give rise to damage. The kickstart function ensures fan output is set to 100 % for a set time (1...10 s) thereby making sure the starting torque is exceeded. Kickstart is activated when the lowest fan speed is selected. The function is also active during manual fan control. After the set time (1...10 s) has elapsed, the fan will return to its original speed.

Cooling when using electric heater

When using RCF-230CTD(-EC) with an electric heater, the fan will run for an additional 2 minutes after the heater has been shut down in order to cool it off.

NOTE: RCF-230CTD(-EC) has no indication capable of showing if the fan breaks or if the heater should overheat. This requires all safety connections to be made externally. An overheating protection or similar can be used to cut the supply voltage.

Chapter 13 Change-over

Change-over is a function enabling installations using only 2-pipe systems to use the same pipe for both heating and cooling depending on whether heating or cooling is required during, for instance, the summer months (Cooling control) or winter months (Heating control).

All controllers in the RCF range have a change-over function, but the RCFM models offer manual change-over. Input may consist of either an analogue PT1000 sensor, or of a closing contact connected to a universal input (FS = no sensor connected).

The PT1000 sensor must be mounted so that it can measure the temperature on the supply pipe to the coil. Should this fall below 16°C (FS), change-over is activated and cooling controlled on the output, AO1 alt. DO4 (TD- and D models). If the temperature rises above 28°C (FS), the change-over function is turned off and heating is controlled on the output.

On models with manual change-over, control modes are changed manually using the "M" button. Alternatively, a potential-free contact can be used. The input function can be set to NO/NC. FS = NO. In this mode, when the contact is open, heating is controlled. A closed contact will initiate control of cooling.

Change-over can also be controlled via a central command. See list of variables contained in the last section of the manual.

Chapter 14 Display handling

The display is handled using the buttons on the controller: See [chapter 10](#) for more information.

Display indications

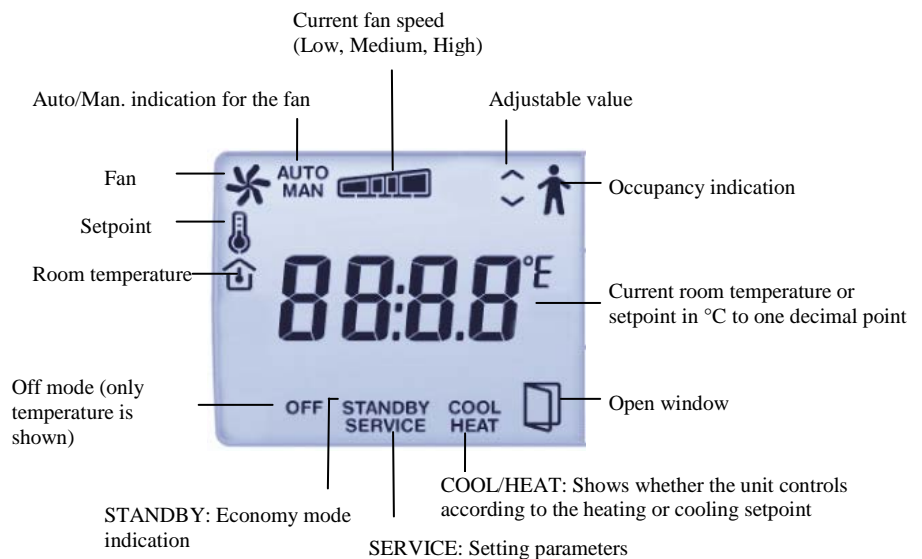

Figure 7. Indications in the display

The parameter menu

When the controller is in Comfort or Window mode, different parameter settings may be adjusted in a parameter menu. This menu appears if the INCREASE and DECREASE buttons are pressed simultaneously for approx. 5 seconds until the Service indication appears in the display. Thereafter, the INCREASE button should be pressed twice.

Initially, only a parameter number (P01, P02, P03 etc.) is shown in the parameter menu. By pressing the INCREASE and DECREASE buttons, the parameters can be cycled through. When the correct parameter is selected, the On/Off button is pressed (or, on the RCFM, the Fan button), after which the parameter's value is shown and the parameter number disappears. The parameters value may now be changed using the INCREASE and DECREASE buttons. By depressing the INCREASE or DECREASE button, the value shown in the display is initially only changed slowly. The changing speed thereafter increases in steps of approx. 3-4 steps with 2-3 seconds in between.

Confirm/Undo

To confirm changing the parameter, the On/Off button (or, in case of the RCFM, the Fan button) is pressed once more. The display will then return to showing the parameter number. Before the change is confirmed, the original value (i.e. the value from before the change took place) can be returned by pressing the INCREASE and DECREASE buttons simultaneously. The original value will then return in the display.

Return

After approx. 1 minute, or when INCREASE and DECREASE is pressed simultaneously while in the menu, the display will return to its normal view mode. The text Exit is shown after the last parameter in the display. Pressing the On/Off button (or, in case of the RCFM, the Fan button) when Exit is shown will eject the user from the parameter menu. Press INCREASE to go to the first parameter and DECREASE to go to the last parameter.

Parameters

Below, all parameters are presented. Please refer to the enclosed instructions to see which parameters specifically apply to your controller. The following parameters can be changed in the parameter menu:

Number of parameter	Description	Factory setting (FS)
1	Control modes 2=2-pipe system 3=4-pipe system 4=Electric heater	3 (2 for RCFM-230(C)D and RCFM-230(C)TD)
2	Change-over mode: 0=Heating control 1=Cooling control 2= Automatic change-over depending on analogue temperature sensor or digital input	2
3	Operating mode when activating digital input 1: 0=Economy mode (presence) 1=Off mode (windows)	0
4	Mould protection: 0=Not active 1=Active (the fan never stops, even when in controller off mode)	0
5	DB, deadband at Comfort. If the deadband is 2 K, the heating setpoint equals the setpoint minus 1 and the cooling setpoint equals the setpoint plus 1.	2 K
6	Heating setpoint during absence.	15°C
7	Cooling setpoint during absence.	30°C
8	P-band for the room controller.	10 K
9	I time for the room controller.	300 s
10	Hysteresis (ΔT).	1 K
11	Switch-off timer for Comfort mode.	0 min
12	Power-on-delay for Comfort mode.	0 min
13	Sensor connected to AI1: 0=Internal sensor 1=External room sensor 11=Supply air temperature limitation sensor	0
14	Sensor connected to UI1: 0=None 1=Change-over digital 2=Change-over analogue 3=Off mode (open window)	0
15	Type of digital actuator: 0=Thermal 1=3-position	0
16	Output signal for actuator connected to AO1: 0=0...10 V 1=2...10 V 2=10...2 V 3=10...0 V	0

Number of parameter	Description	Factory setting (FS)
17	Output signal for actuator connected to AO2: 0=0...10 V 1=2...10 V 2=10...2 V 3=10...0 V	0
18	Period time for heating actuator if thermal actuators.	60 s
19	Period time for cooling actuator if thermal actuators.	60 s
20	Run time for heating actuator with increase/decrease actuators.	120 s
21	Run time for cooling actuator with increase/decrease actuators.	120 s
22	Time (in hours) between exercise of heating actuator.	23
23	Time (in hours) between exercise of cooling actuator.	23
24	Setpoint or actual value shown in display: 0=Actual, setpoint when changing setpoint value 1=Actual, setpoint displacement when changing setpoint displacement 2=Setpoint 3=Only setpoint displacement	2
25	Configuration of fan control: 0=No control 1=The fan is controlled by the heating requirement 2=The fan is controlled by the cooling requirement 3=The fan is controlled by both the heating and cooling requirement When using an electric heater this parameter should only be set to 1 or 3, otherwise there is a risk of overheating.	3
26	Start signal in % for controller output, heating or cooling, for fan speed 1.	20 (5 when using electric heater)
27	Start signal in % for controller output, heating or cooling, for fan speed 2.	60
28	Start signal in % for controller output, heating or cooling, for fan speed 3.	100
29	Hysteresis for start/stop of fans in % of controller output.	5
30	Number of fan speeds.	3
31	Fan speed in Auto mode: 0 = The lowest fan speed is "stop" 1 = The fan will never stop except when in the controller off mode. The lowest possible speed is limited to the lowest speed of the fan.	1
32	Temperature compensation on AII.	0 K
33	Temperature compensation for internal room sensor.	0 K
34	Maximum permitted upward setpoint offset. Settable value=0...13 K.	13 K
35	Maximum permitted downward setpoint offset. Settable value=0...17 K.	17 K
36	NO/NC* digital input 1: 0=NO 1=NC	0
37	NO/NC* universal input 1: 0=NO 1=NC	0
38	NO/NC* digital output 4: 0=NO 1=NC	1
39	NO/NC* digital output 5: 0=NO 1=NC	1

Number of parameter	Description	Factory setting (FS)
40	Manual/Auto heating output signal: 0=Off 1=Manual 2=Auto	2
41	Manual/Auto cooling output signal: 0=Off 1=Manual 2=Auto	2
42	Heating output signal in manual mode.	0
43	Cooling output signal in manual mode.	0
44	Model.	-
45	Major version.	-
46	Branch version.	-
47	Launched version or beta version.	-
48	Revision.	-
49	Display backlight low	10
50	Display backlight high	30
51	EXOline PLA-address	FS
52	EXOline ELA-address	FS
53	Modbus address	254
54	Parity and stop bits for Modbus communication: 0 = 8N2 1 = 8O1 2 = 8E1 3 = 8N1	2
55	Modbus timeout for characters (t1.5), in ms. Should be 3.5 times a character, ie. at least 2 ms.	2
56	Response lag Modbus (t3.5), in ms. Should be 3.5 times a character, ie. at least 5 ms.	5
57	Communication protocol: 0 = Automatic EXOline or Modbus 1 = BACnet MS/TP	0
58	BACnet MS/TP MAC address: 0-127	FS (0-99)
59	BACnet MS/TP, device id, the 4 lowest digits. Ex. 4567 in 1234567	FS
60	BACnet MS/TP, device id, the 3 highest digits. Ex. 123 in 1234567	FS
61	BACnet MS/TP, maximum number of master units	127
62	Speed for communication protocol: 0 = 9600 bps 1 = 19200 bps 2 = 38400 bps 3 = 76800 bps	0
63	Set communication parameters to factory settings (does not apply to addresses): 1 = Factory settings (EXOline/Modbus@9600)	0
64	Basic setpoint for RCF, 5...50°C (0...100°C with Regio tool [®])	22

Number of parameter	Description	Factory setting (FS)
65	Setting, active buttons RCF: 0 = No active buttons 1 = Only On/Off button active 2 = Only Up/Down buttons active 3 = On/Off and Up/Down buttons active 4 = Only fan button active 5 = On/Off and fan button active 6 = Up/Down and fan button active 7 = All buttons active RCFM: 0 = No active buttons 1 = Only On/Off button active 2 = Only Up/Down buttons active 3 = On/Off and Up/Down buttons active 4 = Only M button active 5 = Fan and M buttons active 6 = Up/Down and M buttons active 7 = All buttons active	7
66	Function to prevent users from manually setting the fan speed if the fan should not run due to cooling/heating output, as specified in parameter 25. 0 = Not active 1 = Active	0
67	The EC fan will start when the output exceeds the set value. (only RCF-230CTD-EC)	10
68	The maximum speed of the EC fan (only RCF-230CTD-EC)	100
69	Fan kickstart. The fan will run 100 % when starting up for the set time, 0...10 seconds.	0
70	Supply air max limitation for cascade control and heating control	35°C
71	Supply air min limitation for cascade control and heating control	24°C
72	Supply air max limitation for cascade control and cooling control	24°C
73	Supply air min limitation for cascade control and cooling control	12°C
74	Cascade factor between room controller and supply air controller	3°C
75	Frost protection temperature for supply air when supply air temperature limitation is active	8°C
76	Activate supply air temperature limitation for: 0 = Heating control 1 = Cooling control 2 = Both heating and cooling control	1

*NO = Normally Open, NC = Normally Closed

Chapter 15 Memory functions during power failure

During a power failure, the controller has an integrated function that enables settings and configuration to be stored in a so-called non-volatile memory (EEPROM). Settings and configurations are saved in the memory whenever they are changed, so that the latest values are always stored. However, measurements and other variables utilised by the controller during normal operation, and which tend to fluctuate continually, are not saved.

Values can be saved approximately 100 000 times to this non-volatile memory. Changed settings should therefore not be sent systematically and with great frequency to the controller via network communication. Sending normal changes via the network - e.g. such as changing the running mode a few times per day - will however present no problems.

Example

Activating the occupancy detection will not be saved to memory. Rather, the controller will return to its current mode after powering up.

Chapter 16 Modbus signal types

EXOL types

EXOL signal types:

R = Floating point number (Real) (-3.3E38 - 3.3E38)

I = Whole number (Integer) (-32768 - 32767)

X = Index (0 - 255)

L = Logic (Logic) (0/1)

Modbus types

Modbus signal types (types listed below):

1 = Coil Status Register (Modbus function = 1, 5 and 15)

2 = Discrete Input (Modbus function = 2)

3 = Coil Status Register (Modbus function = 3, 6 and 16)

4 = Input Register (Modbus function = 4)

Supports the following Modbus functions:

1 = Read Coils

2 = Read Discrete Input

3 = Read Holding Register

4 = Read Input Register

5 = Write Single Coil

6 = Write Single Register

15 = Write Multiple Coils

16 = Write Multiple Registers

Scaling factor Modbus

All floating point numbers have a scaling factor of 10. Integers, Index and Logic signals always have a scaling factor of 1.

EXOline/Modbus

The RCF controller will automatically switch between EXOline and Modbus, depending on what type of communication is used. This switch-over will take place without any errors in communication resulting. The exception is when communicating via Modbus with a configuration of 8 bits, no parity and 1 stop bit, in which case the switch must be made manually.

Wiring, Modbus

A Modbus type protocol consists of multiple layers (OSI model). The bottom layer is always the physical layer, the number of connection wires and signal levels. The next layer describes the communication digits (number of bits, stop bits, parity bits etc). After these come the layers describing Modbus-specific functions (number of digits per message, the meaning of different messages, etc). For Modbus, the bottom layer can be either RS485, RS422 or RS232.

RS485 and RS422

RS485 and RS422 constitute the purely electrical part of the protocol, ie. the physical layer. RS485 has two connections, A and B. Often, there is also a Protective earth (N on EXO controllers). RS485 units are connected A → A and B → B. It may prove necessary to shift A and B in order to make Modbus work properly. RS485 is a so called half duplex communication: The communication can only go in one direction, eg. the main unit will initially send a request, and thereafter listen to the reply. A and B are used both for sending and receiving.

RS422 is a full duplex communication, meaning that 4 connecting wires are required; 2 for sending (Tx+ and Tx-) and 2 for receiving (Rx+ and Rx-). Tx is used for sending and Rx for receiving, meaning the Tx in a unit must be connected to the Rx in another and vice versa. Pertaining to signal levels, etc., RS422 and RS485 are identical.

In order to connect RS485 and RS422: Connect Tx+ to Rx+ and Tx- to Rx- on the RS422 unit. We have now changed a 4-wire system to a 2-wire system and can connect them to A and B on the RS485 unit. It is usually easiest to find out what fits where simply by experimenting. Wrong polarity makes the system not function, but is incapable of harming any unit.

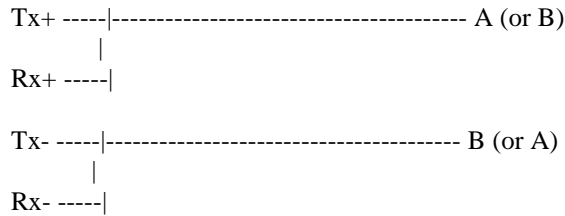

Bit rate, two stop bits, parity is next layer.

These settings must correspond to the settings in the main unit. Find out what the settings for the main unit are, and then enter the same settings into the controller.

Parity can be set to odd, even (FS) or none. If no parity is set, two stop bits will automatically be used. If odd or even parity is set only one stop bit will be used, or the total amount of bits will be too great. 1 start bit, 8 data bits, 1 parity bit and 1 stop bit gives a total of 11 bits, which is the maximum.

Chapter 17 Modbus signals

Discrete inputs

Name of signal	Type	Modbus address	Description
RC_Actual_L.RegioDigIn(0)	L,2	1	Not used
RC_Actual_L.RegioDigIn1	L,2	2	Value on digital input 1
Not used in this model	L,2	3	
RC_Actual_L.RegioUDigIn1	L,2	4	Value on universal digital input 1
RC_Actual_L.RegioDigOut(0)	L,2	5	Not used
RC_Actual_L.RegioDigOut1	L,2	6	Value on digital output 1
RC_Actual_L.RegioDigOut2	L,2	7	Value on digital output 2
RC_Actual_L.RegioDigOut3	L,2	8	Value on digital output 3
Not used in this model	L,2	9-10	
RC_Actual_L.RegioUDigOut1	L,2	11	Heating (Value on digital output 4)
RC_Actual_L.RegioUDigOut2	L,2	12	Cooling (Value on digital output 5)
RC_Actual_L.RegioDIOpenWindow	L,2	13	Indicates open window
Not used in this model	L,2	14	
RC_Actual_L.RegioDIPresences	L,2	15	Indicates presence from digital input
RC_Actual_L.RegioDIChangeOver	L,2	16	Indicates change-over from digital input
RC_Actual_L.RegioFanSpeed1	L,2	17	Indicates fan speed 1
RC_Actual_L.RegioFanSpeed2	L,2	18	Indicates fan speed 2
RC_Actual_L.RegioFanSpeed3	L,2	19	Indicates fan speed 3
Not used in this model	L,2	20	
RC_Actual_L.RegioCVHeatPulsProp	L,2	21	Indicates pulse prop. heating
RC_Actual_L.RegioCVCoolPulsProp	L,2	22	Indicates pulse prop. cooling
RC_Actual_L.RegioCVHeatInc	L,2	23	Indicates increase heating/cooling DO4
RC_Actual_L.RegioCVHeatDec	L,2	24	Indicates decrease heating/cooling DO5
Not used in this model	L,2	25-26	
RC_Actual_L.RegioAIChangeOverState	L,2	27	Indicates change-over status from analogue input
RC_Actual_L.RegioChangeOverState	L,2	28	Indicates change-over status from both digital and analogue input
Not used in this model	L,2	29-30	
RC_Actual_L.RegioPresence	L,2	31	Occupancy indication (with on- and switch-off delay)
Not used in this model	L,2	32-33	

Coil status register

Name of signal	Type	Modbus address	Default value	Description
Not used in this model	L,1	1	0	
RC_Setp_L.RegioShutDown	L,1	2	0	Puts the unit in Shutdown mode.
RC_Setp_L.RegioFireAlarmStop	L,1	3	0	Places the unit in Shutdown mode and prevents it from being activated again, unless this value is first set to "0".
RC_Setp_L.RegioDiNC(0)	L,1	4	0	Not used
RC_Setp_L.RegioDi1NC	L,1	5	0	Normally open (NO) or normally closed (NC) on digital input. 0=NO, 1=NC.
Not used in this model	L,1	6	.	
RC_Setp_L.RegioUDi1NC	L,1	7	0	Normally open (NO) or normally closed (NC) on universal digital input. 0=NO, 1=NC.
Not used in this model	L,1	8	-	
RC_Setp_L.RegioDO4NC	L,1	9	1	DO4 NO/NC
RC_Setp_L.RegioDO5NC	L,1	10	1	DO5 NO/NC
RC_Setp_L.RegioDilAct	L,1	11	0	DI1-activation (presence/window) → Economy/Off
RC_Setp_L.RegioMPAct	L,1	12	0	Activation of Mould protection.
RC_Setp_L.RegioTermoModel	L,1	13	0	EEPROM storage of Thermo model variable (3-point actuator)
RC_Setp_L.RegioMinFanSpeed	L,1	14	1	The fan is run at its minimum speed setting if the automatic fan control calculates that the fan can be switched off.
Not used in this model	-	15	-	
RC_Setp_L.RegioComFactoryDefaults	L,1	16	0	Set communication parameters to factory settings (does not apply to addresses): 1 = Factory settings (resets to 0)
RC_Setp_L.RegioBlockConfig	L,1	21	0	Blocks the option to enter the parameter list using the buttons on RCF.
RC_Setp_L.RegioPreventManualFanSpeed	L,1	22	0	Prevents the fan speed from being changed manually if the fan is not set to auto (parameter 25).

Input register

Name of signal	Type	Modbus address	Description
RC_Actual_X.RegioSoftware	X,4	1	Type of Regio software: 0 = RCP 1 = RC
RC_Actual_X.RegioVerMajor	X,4	2	Major version
RC_Actual_X.RegioVerMinor	X,4	3	Minor version
RC_Actual_X.RegioVerBranch	X,4	4	Branch version
RC_Actual_X.RegioRevision	X,4	5	Revision
Not used in this model	X,4	6	
RC_Actual_X.RegioUnitState	X,4	7	Current running mode: 0 = Off 1 = Economy/Standby 2 = Not used 3 = Not used 4 = Comfort
RC_Actual_X.RegioControllerState	X,4	8	Current control: 0 = Off 1 = Heating 2 = Cooling
RC_Actual_X.RegioFanSpeed	X,4	9	Current fan speed: 0 = Off 1 = Fan speed 1 active 2 = Fan speed 2 active 3 = Fan speed 3 active
Not used in this model	X,4	10	
RC_Actual_R.RegioRoomTemp	R,4	11	Room temperature
RC_Actual_R.RegioRoomTempExt	R,4	12	Room temperature from external sensor
RC_Actual_R.RegioRoomTempInt	R,4	13	Room temperature from internal sensor
RC_Actual_R.RegioAIChangeOver	R,4	14	Change-over temperature
RC_Actual_R.RegioAnaIn1	R,4	15	Value on analogue input 1
RC_Actual_R.RegioUAnaIn1	R,4	16	Value on universal analogue input 1
RC_Actual_R.RegioUAnaOut1	R,4	17	Value on universal analogue output 1
RC_Actual_R.RegioUAnaOut2	R,4	18	Value on universal analogue output 2
Not used in this model		19	
RC_Actual_R.RegioPIDSetP	R,4	20	Controller setpoint
RC_Actual_R.RegioPIDOutput	R,4	21	Controller output signal (0...100 %)
RC_Actual_R.RegioHeatOutput	R,4	22	Heating output signal (0...100 %)
RC_Actual_R.RegioCoolOutput	R,4	23	Cooling output signal (0...100 %)
RC_Actual_R.RegioAI1Raw	R,4	24	Raw value for analogue input 1
RC_Actual_R.RegioUI1Raw	R,4	25	Raw value for universal input 1
RC_Actual_R.RoomTemp_NTC2	R,4	26	Room temperature input value from secondary internal sensor
RC_Actual_R.RegioSupplyAirTemp	R, 4	47	Supply air temperature from sensor connected to AI1
RC_Actual_R.RegioSupplyAirPIDout	R, 4	48	Supply air controller output
RC_Actual_R.RegioPID2Setp	R, 4	49	Room controller output (scaled) and supply air controller setpoint

Holding register

Name of signal	Type	Modbus address	Default setting	Description
Not used in this model	X,3	1-2	-	
RC_Setp_X.RegioHeatOutputSelect	X,3	3	2	Manual/Auto heating output
RC_Setp_X.RegioCoolOutputSelect	X,3	4	2	Manual/Auto cooling output
RC_Setp_X.RegioFanSelect	X,3	5	4	Select fan mode: 0 = Off 1 = Manual speed 1 2 = Manual speed 2 3 = Manual speed 3 4 = Auto
RC_Setp_X.RegioFanControlMode	X,3	6	3	Select fan control: 0 = No control 1 = The fan is controlled by heating requirement 2 = The fan is controlled by cooling requirement 3 = The fan is controlled by both heating and cooling requirement
RC_Setp_X.RegioFanSpeed1Start	X,3	7	20	Controller output signal in % for fan speed 1
RC_Setp_X.RegioFanSpeed2Start	X,3	8	60	Controller output signal in % for fan speed 2
RC_Setp_X.RegioFanSpeed3Start	X,3	9	RCFx-230CD = 90 All others = 100	Controller output signal in % for fan speed 3
RC_Setp_X.RegioFanSpeedHyst	X,3	10	5	Controller output signal hysteresis start/stop fan speed
RC_Setp_X.RegioFanSpeedMax	X,3	11	3	Number of fan speeds (1-3)
Not used in this model	X,3	12	-	
RC_Setp_X.RegioChangeOverSelect	X,3	13	RCFM-230Cxx = 0 RCF-230Cxx = 2	Manual/Auto Change-over (0=Heating, 1=Cooling, 2=Auto)
RC_Setp_X.RegioRemoteState	X,3	14	5	Used for remote control: 0 = Off 1 = Economy/Standby 2 = Not used 3 = Not used 4 = Comfort 5 = No remote control
RC_Setp_X.RegioUnitReturnState	X,3	15	-	Pre-set running mode: 0 = Off 1 = Standby
Not used in this model	X,3	16		
Not used in this model	X,3	17	-	

Name of signal	Type	Modbus address	Default setting	Description
RC_Setp_X.RegioControllerMode	X,3	18	RCFM-230Cxx = 2 RCF-230Cxx = 3	Control mode selection: 2= Heating or Cooling via change-over 3 = Heating/Cooling 4 = Electric heating
RC_Setp_X.RegioCVHeatType	X,3	19	0	Type of actuator, heating: 0 = 0...10 V 1 = 2...10 V 2 = 10...2 V 3 = 10...0 V
RC_Setp_X.RegioCVCoolType	X,3	20	0	Type of actuator, cooling
RC_Setp_X.RegioCVHeatExerciseInterval	X,3	21	23	Time (in hours) between exercise of heating actuator.
RC_Setp_X.RegioCVCoolExerciseInterval	X,3	22	23	Time (in hours) between exercise of cooling actuator.
Not used in this model	X,3	23	-	
RC_Setp_X.RegioAi1	X,3	24	0	Signal connected on AI1: 0 = Not used (Internal Room sensor used) 1 = External Room sensor 3-10 = No function 11 = Supply air temperature limitation sensor
Not used in this model	X,3	25-27	-	
RC_Setp_X.RegioDi2	X,3	28	N/A	Not used (Signal connected on DI2: 1 = Open window 2 = Condensation alarm)
RC_Setp_X.RegioDi3	X,3	29	N/A	Not used
RC_Setp_X.RegioUi1	X,3	30	0	Signal connected on UI1: 0 = Not used 1 = Change-over sensor, digital 2 = Change-over sensor, analogue 3=Off mode (open window)
Not used in this model	X,3	31 - 41	-	
RC_Setp_X.RegioUo1	X,3	42	RCF-230CAD = 3 RCF-230CTD-EC = 17 All others = 1	Signal connected on UO1: 0 = Not used 1 = Thermo valve, Heating/Cooling (not (C)AD) 2 = Not used 3 = Analogue valve Heating/Cooling (only (C)AD) 4-16 = Not used 17 = EC fan analogue out AO1, Thermo valve heating DO4 (only RCF-230-CTD-EC)

Name of signal	Type	Modbus address	Default setting	Description
RC_Setp_X.RegioUo2	X,3	43	RCF-230CAD = 4 All others = 2	Signal connected on UO2: 0 = Not used 1 = Not used 2 = Thermo valve, Cooling (not (C)AD) 3 = Not used 4 = Analogue valve Cooling (only (C)AD)
RC_Setp_X.RegioModbusSlaveAddr	X,3	44	Factory set	Address Modbus slave
RC_Setp_X.RegioModbusParity	X,3	45	2	Parity and stop bits for Modbus communication: 0 = 8N2 1 = 8O1 2 = 8E1 3 = 8N1
RC_Setp_X.RegioModbusCharTimeout	X,3	46	3	Modbus timeout for characters (t1.5), in ms. Should be 1.5 times a character, ie. at least 2 ms.
RC_Setp_X.RegioModbusAnswerDelay	X,3	47	5	Response lag Modbus (t3.5), in ms. Should be 3.5 times a character, ie. at least 5 ms.
RC_Setp_X.RegioDispBacklightLO	X,3	48	10	Display backlight low (0...100)
RC_Setp_X.RegioDispBacklightHi	X,3	49	30	Display backlight high (0...100)
RC_Setp_X.RegioDispContrast	X,3	50	15	Contrast (0...15)
RC_Setp_X.RegioDisplayViewMode	X,3	51	2	Viewing options for the display: 0 = Room temperature and setpoint when adjusting 1 = Room temperature and setpoint when adjusting 2 = Setpoint 3 = Setpoint displacement
Not used in this model	X,3	52-55	-	
Not used in this model	I,3	56	-	
RC_Setp_I.RegioPresenceOffTime	I,3	57	0	Switch-off delay when changing to no presence (min)
RC_Setp_I.RegioPresenceOnTime	I,3	58	0	Switch-on delay when changing to presence (min)
RC_Setp_I.RegioCVHeatPeriodTime	I,3	59	60	Period time for pulse prop. control valve, heating (sec)
RC_Setp_I.RegioCVCoolPeriodTime	I,3	60	60	Period time for pulse prop. control valve, cooling (sec)
RC_Setp_I.RegioCVHeatRunTime	I,3	61	120	Run time closed valve to open, heating (sec)
RC_Setp_I.RegioCVCoolRunTime	I,3	62	120	Run time closed valve to open, cooling (sec)
Not used in this model	X,3	63-67	-	
Not used in this model	R,3	68-69	-	
RC_Setp_R.RegioStandbySetPDeadBand	R,3	70	8°C	Deadband for Economy mode

Name of signal	Type	Modbus address	Default setting	Description
RC_Setp_R.RegioUnOccSetPHeat	R,3	71	15°C	Heating setpoint when in Unoccupied mode
RC_Setp_R.RegioUnOccSetPCool	R,3	72	30°C	Cooling setpoint when in Unoccupied mode
RC_Setp_R.RegioFrostSetP	R,3	73	N/A	Not used
RC_Setp_R.RegioSetpointOffsetPos	R,3	74	13°C	Max. upward setpoint displacement
RC_Setp_R.RegioSetpointOffsetNeg	R,3	75	17°C	Max. downward setpoint displacement
RC_Setp_R.RegioSetPOffset	R,3	76	0	Setpoint displacement
RC_Setp_R.RegioPIDPGain	R,3	77	10°C	Room controller P-band
RC_Setp_R.RegioPIDITime	R,3	78	300 sec	Room controller I time
RC_Setp_R.RegioCVDeadband	R,3	79	N/A	Not used (Control valve dead band)
RC_Setp_R.RegioAIChangeOverLimitLow	R,3	80	18°C	Controller switches over to control of cooling if change-over temperature is lower
RC_Setp_R.RegioAIChangeOverLimitHigh	R,3	81	28°C	Controller switches over to control of heating if change-over temperature is higher
RC_Setp_R.RegioAi1Comp	R,3	82	0°C	Compensation for analogue input 1
RC_Setp_R.RegioUi1Comp	R,3	83	0°C	Compensation for universal input 1
RC_Setp_R.RegioInternalTempComp	R,3	84	0°C	Compensation for internal room sensor
RC_Setp_R.RegioTempFilterFactor	R,3	85	0.2°C	Filter factor for temperature on analogue input 0 = No filter 1 = Max filter
Not used in this model	R,3	86-89	-	
RC_Setp_R.RegioThermostatHyst	R,3	90	10	Room hysteresis
RC_Setp_R.RegioComfortSetPDeadBand	R,3	91	RCFM-230Cxx = 0 RCF-230Cxx = 2	Deadband for Comfort mode (DB)
	R,3	92	-	Not used
	R,3	93	-	Not used
RC_Setp_R.RegioHeatOutputManual	R,3	94	0 %	Manual output heating output (0...100 %)
RC_Setp_R.RegioCoolOutputManual	R,3	95	0 %	Manual output cooling output (0...100 %)
RC_Setp_R.RegioRoomTempRemote	R,3	96	-255	Used for remote control of room temperature. External Room sensor must be selected.
RC_SetpExt_R.RegioMinECFanSpeed	R,3	282	1 V	Starting voltage for EC fan. The fan will never receive a signal of a lower voltage than the set value (only RCF-230CTD-EC).

Name of signal	Type	Modbus address	Default setting	Description
RC_SetpExt_R.RegioMaxECFanSpeed	R,3	283	10 V	Maximum speed of the EC fan
RC_SetpExt_R.RegioRCFSetPoint	R,3	284	22°C	Basic setpoint
RC_Setp_R.SupplyAirTLim_HeatHi	R, 3	289	35°C	Supply air max limitation for cascade control and heating control
RC_Setp_R.SupplyAirTLim_HeatLo	R, 3	290	24°C	Supply air min limitation for cascade control and heating control
RC_Setp_R.SupplyAirTLim_CoolHi	R, 3	291	24°C	Supply air max limitation for cascade control and cooling control
RC_Setp_R.SupplyAirTLim_CoolLo	R, 3	292	12°C	Supply air min limitation for cascade control and cooling control
RC_Setp_R.SupplyAirTLim_CascadeFact	R, 3	293	3°C	Cascade factor between room controller and supply air controller
RC_Setp_R.SupplyAirTLim_FrostProtect	R, 3	294	8°C	Frost protection temperature for supply air when supply air temperature limitation is active

Chapter 18 BACnet signal types

BACnet	In order to communicate via BACnet, the protocol has to be changed either via Regio tool [®] or via the parameter list in the display. Once the protocol has been set to BACnet, it can only be switched back to EXOline and Modbus via the display.
Object type	The BACnet types of the signals (types in the list below): <ul style="list-style-type: none">• Analogue inputs• Analogue values• Binary inputs• Binary values• Loop• Multistate inputs• Multistate values• Device
Out_of_service	The property out_of_service is not writable for all Object Types.
Commandable	The value objects are not commandable (i.e. does not use a priority array).
EDE files	EDE files for BACnet are included in the Regio tool [®] installation.

Chapter 19 BACnet signals

Analogue inputs

Object name	Object ID	Description	Unit	Writeable
RC_Actual_R.RegioRoomTemp	Analog input, 0	Room temperature	°C	No
RC_Actual_R.RegioAIChangeOver	Analog input, 1	Change-over temperature	°C	No
RC_Actual_R.RegioAnaIn1	Analog input, 2	Value on analogue input 1	°C	No
RC_Actual_R.RegioUAnaIn1	Analog input, 3	Value on universal analogue input 1	V	No
RC_Actual_R.RegioSupplyAirTemp	Analog input, 4	Supply air temperature	°C	No

Analogue values

Object name	Object ID	Description	Unit	Writeable
RC_Actual_R.RegioUAnaOut1	Analog value, 0	Value on universal analogue output 1	V	No
RC_Actual_R.RegioUAnaOut2	Analog value, 1	Value on universal analogue output 2	V	No
RC_Actual_R.RegioSetPAdjustment	Analog value, 2	Setpoint displacement from internal unit	°C	No
RC_Actual_R.RegioPIDSetP	Analog value, 3	Controller setpoint	°C	No
RC_Actual_R.RegioPIDOutput	Analog value, 4	Controller output	%	No
RC_Actual_R.RegioHeatOutput	Analog value, 5	Heating control	%	No
RC_Actual_R.RegioCoolOutput	Analog value, 6	Cooling control	%	No
Not used in this model	Analog value, 7-8			Yes
RC_Setp_R.RegioUnOccSetPHeat	Analog value, 9	The room heating setpoint when in “Economy” mode	°C	Yes
RC_Setp_R.RegioUnOccSetPCool	Analog value, 10	The room cooling setpoint when in “Economy” mode	°C	Yes
Not used in this model	Analog value, 11			
RC_Setp_R.RegioSetPOffset	Analog value, 12	Setpoint displacement during presence	°C	Yes
RC_Setp_R.RegioHeatOutputManual	Analog value, 13	Manual value heating output	%	Yes
RC_Setp_R.RegioCoolOutputManual	Analog value, 14	Manual value cooling output	%	Yes

Object name	Object ID	Description	Unit	Writeable
RC_Setp_R.RegioRoomTempRemote	Analog value, 15	Remote control of room temperature.	°C	Yes
RC_Setp_R.RegioStandbySetPDeadBand	Analog value, 16	Deadband for Standby mode	°C	Yes
Not used in this model	Analog value, 17-26			
RC_Setp_R.RegioMinECFanSpeed	Analog value, 27	Lowest possible speed for the EC fan	%	Yes
RC_Setp_R.RegioMaxFanSpeed	Analog value, 28	Highest possible speed for the EC fan	%	Yes
RC_Setp_R.RegioAIChangeOverLimitLow	Analog value, 29	Cooling if lower change-over temperature	°C	Yes
RC_Setp_R.RegioAIChangeOverLimitHigh	Analog value, 30	Heating if higher change-over temperature	°C	Yes
RC_Setp_R.RegioThermostatHyst	Analog value, 31	Room temperature hysteresis	°C	Yes
RC_Setp_R.RegioComfortSetPDeadband	Analog value, 32	Deadband for comfort mode.	°C	Yes
RC_SetpExt_R.RegioRCFSetPoint	Analog Value, 33	Basic setpoint for the controller	°C	Yes
RC_Actual_R.RegioPID2Setp	Analog Value, 34	Calculated supply air setpoint	°C	No

Binary inputs

Object name	Object ID	Description	Values	Writeable
RC_Actual_L.RegioDIOpenWindow	Binary input, 0	Indicates open window	ACTIVE/ INACTIVE	No
Not used in this model	Binary input, 1			No
RC_Actual_L.RegioDIPresences	Binary input, 2	Indicates presence from digital input	ACTIVE/ INACTIVE	No
RC_Actual_L.RegioDIChangeOver	Binary input, 3	Indicates change-over from digital input	ACTIVE/ INACTIVE	No
Not used in this model	Binary input, 4-6			No

All binary inputs have normal polarity

Binary values

Object name	Object ID	Description	Values	Writeable
Not used in this model	Binary value, 0			No
RC_Actual_L.RegioCVHeatPulsProp	Binary value, 1	Indicates pulse prop. heating	ACTIVE/ INACTIVE	No
RC_Actual_L.RegioCVCoolPulsProp	Binary value, 2	Indicates pulse prop. cooling	ACTIVE/ INACTIVE	No
RC_Actual_L.RegioCVHeatInc	Binary value, 3	Indicates heating increase	ACTIVE/ INACTIVE	No
RC_Actual_L.RegioCVHeatDec	Binary value, 4	Indicates heating decrease	ACTIVE/ INACTIVE	No
Not used in this model	Binary value, 5-6			No
RC_Actual_L.RegioChangeOverState	Binary value, 7	Indicates change-over status from both digital and analogue input	ACTIVE/ INACTIVE	No
Not used in this model	Binary value, 8			No
RC_Actual_L.RegioFireAlarmStop	Binary value, 9	Places the unit in Shutdown mode and prevents it from being activated again, unless this value is first set to "0".	ACTIVE/ INACTIVE	Yes
RC_Setp_L.RegioShutDown	Binary value, 10	Places the unit in Shutdown mode	ACTIVE/ INACTIVE	Yes
RC_Setp_L.RegioBlockConfig	Binary value, 12	Prevents parameter menu access via display	ACTIVE/ INACTIVE	Yes

All binary values have normal polarity

Loop

Object name	Object ID	Description
Controller	Loop, 0	The Regio controller

Multistate inputs

Object name	Object ID	Description	Values	Writeable
Not used in this model	Multistate input, 0			No
RC_Actual_X.RegioUnitState	Multistate input, 1	Current running mode	1=Off 2=Economy/Standby 3=Not used 4=Not used 5=Comfort	No
RC_Actual_X.RegioControllerState	Multistate input, 2	Current control mode	1=Off 2=Heating 3=Cooling	No
RC_Actual_X.RegioFanSpeed	Multistate input, 3	Current fan speed	1=Off 2=Fan speed 1 3=Fan speed 2 4=Fan speed 3	No

Multistate values

Object name	Object ID	Description	Values	Writeable
RC_Setp_X.RegioHeatOutputSelect	Multistate value, 0	Manual/Auto heat output	1=Off 2=Manual output 3=Automatic output	Yes
RC_Setp_X.RegioCoolOutputSelect	Multistate value, 1	Manual/Auto cool output	1=Off 2=Manual output 3=Automatic output	Yes
RC_Setp_X.RegioFanSelect	Multistate value, 2	Fan mode select	1=Off 2=Manual speed 1 3=Manual speed 2 4=Manual speed 3 5=Auto 6=Auto 2 7=Auto 1	Yes
Not used in this model	Multistate value, 3	Manual/Auto forced ventilation	1=Off 2=Manual on 3=Auto	Yes
RC_Setp_X.RegioChangeOverSelect	Multistate value, 4	Manual/Auto change-over	1=Heating 2=Cooling 3=Auto	Yes
RC_Setp_X.RegioRemoteState	Multistate value, 5	Remote control unit state	1=Off 2=Economy/Standby 3=Not used 4=Not used 5=Comfort 6=No remote control	Yes

Object name	Object ID	Description	Values	Writeable
RC_Non_Modbus.RegioButtonActiveConf	Multistate value, 6	Buttons active	1=No buttons 2=Occupancy button only 3=INCREASE/DECREASE only 4=Occupancy button and INCREASE/DECREASE 5=Fan button only 6=Occupancy button and fan button 7=INCREASE/DECREASE and fan button 8=All buttons	Yes

Device

The **Device** object contains two writeable properties; **Description** and **Location**. **Description** can be 17 characters in length and **Location** can be 33 characters, as long as single byte character encoding is used.

Index

3

3-position actuators, 31

A

About this manual

- Additional information, 5
- Terms, 5

Additional information, 5

Analogue actuators, 31

Analogue values, 52

Application examples, 7

Automatic control, 32

B

Binary values, 54

C

Cascade control, 26

Change-over, 34

Coil status register, 44

Commissioning, 23

Communication, wiring, 14

Configuration, 13

Confirm/Undo, 35

Control principles, 24

D

Device, 56

Discrete inputs, 43

Display handling, 35

- Display indications, 35

- Parameter menu, 35

Display indications, 35

E

Exercising, 31

F

Fan control, 32

- Automatic control, 32
- Off/Unoccupied, 32

Fire alarm

- Blocking of device, 30

H

Holding register, 46

I

INCREASE/DECREASE buttons, 29, 35

Input register, 45

Inputs

- Analogue, 52

- Binary, 53

- Discrete, 43

- Multistate, 55

Installation, 14

Introduction to RCF, 6

L

Loop, 54

M

Memory functions during power failure, 40

Min and max supply air limitation, 26

Models, 8

Mounting, 6, 14

Multistate values, 55

O

Off, 32

Off/Unoccupied, 32

Operating modes, 28

P

Parameter menu, the, 35

Parameters, 36

R

Register

- Coil status, 44

- Holding, 46

- Input, 45

Return, 36

S

Setpoint

- Basic setpoint, 29

- display of setpoint at setpoint offset, 29

- Setpoint displacement, 29

Setpoint displacement, 29

Signal types, 41

Signals, 43

T

Technical data, 10

Terms, 5

- Thermal actuators, 31
- Troubleshooting, 23
- Types of actuators, 31
 - 3-position actuators, 31
 - Analogue actuators, 31
 - Excercising, 31
 - Exercising, 31
 - Thermal actuators, 31

U

- Using labels, 12

V,W

- Wiring
 - communication, 14
- Wiring for model RCF-230CTD-EC, 18
- Wiring for models RCF(M)-230(C)D, 21
- Wiring for models RCF(M)-230(C)TD, 16
- Wiring for models RCF-230(C)AD, 20

REGIN - THE CHALLENGER IN BUILDING AUTOMATION

AB Regin

Head office

Box 116, S-428 22 Källered,
Sweden

Phone: +46 31 720 02 00

Fax: +46 31 720 02 50

info@regin.se

www.regincontrols.com



THE CHALLENGER IN BUILDING AUTOMATION