

CIRCULATION UNIT

MIXING FUNCTION, SERIES GRA300



GRA311

PRODUCT DESCRIPTION

The ESBE series GRA300 is a circulation mixing unit which is intended for heating circulations where the outstanding flow and temperature control are required. Equipped with two shut-off valves with thermometers, check valve, high class insulation shell and high efficiency circulation pump.

The GRA300 is delivered with the 3-way rotary progressive mixing valve and actuator. The Circulation Mixing Unit ensures best regulation performances independent from flow rate and low oversizing risk thanks to progressive valve characteristic, as well as the working possibility with most controllers available on the market.

SERVICE AND MAINTENANCE

The circulation unit does not require any specific maintenance under normal conditions.

KEY BENEFITS

- Outstanding flow control thanks to the progressive characteristic of the valve
- Ready to use with most controllers available on the market
- High class insulation shell
- Compact design
- "Quick fit" connection between Valve and Actuator

PRODUCT ASSORTMENT

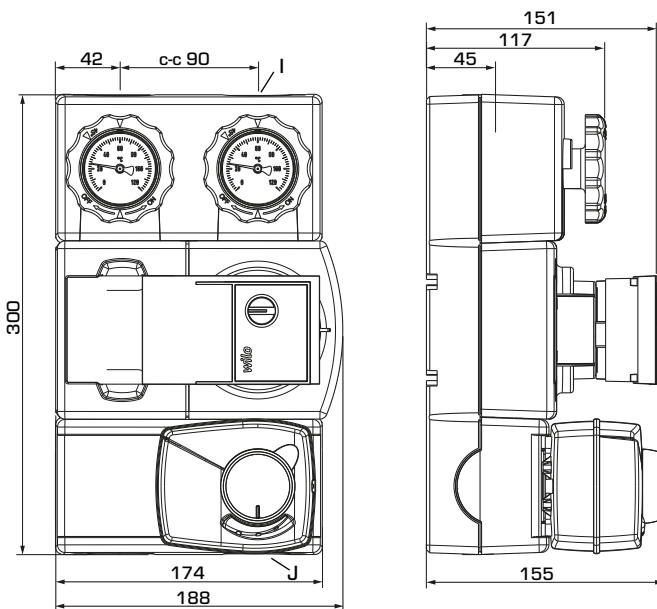

GRA311

SERIES GRA300

Art. No.	Reference	DN	Pump	Connections		Weight [kg]	Note
				I	J		
61043100	GRA311	20	Wilo 15/7,5	G 3/4"	G 1"	4,5	

CIRCULATION UNIT

MIXING FUNCTION, SERIES GRA300

TECHNICAL DATA

 Visit esbe.eu for further detailed information.

The Circulation unit, in general:

Pressure class: _____ PN 6
 Media temperature: _____ max. +110°C
 _____ min. 0°C
 Ambient temperature: _____ max. +50°C
 _____ min. 0°C
 Working pressure: _____ 0,6 MPa (6 bar)
 Connections, _____ Internal thread (G), ISO 228/1
 _____ External thread (G), ISO 228/1
 Insulation: _____ EPP λ 0,036 W/mK
 Media: _____ Heating water (in accordance with VDI2035)
 _____ Water / Glycol mixtures, max. 50%
 (above 20% admixture, the pump data must be checked)
 _____ Water / Ethanol mixtures, max. 28%

Material, in contact with water:

Components of: _____ Steel, Cast iron, Brass
 Sealing material of: _____ PTFE, Aramid fibre, EPDM

EEI (Energy Efficiency Index),

Wilco circulation pump: _____ <0,21

Conformities and certificates:

 LVD 2014/35/EU  ErP 2009/125/EU
 EMC 2014/30/EU  ErP 2015
 RoHS 2011/65/EU  ErEV 2014
 PED 2014/68/EU, article 4.3

The integrated mixing valve:

Max. differential pressure drop: _____ 100 kPa (1 bar)
 Close off pressure: _____ 200 kPa (2 bar)
 Leakrate in % of flow*: _____ < 0,05%
 * Differential pressure 100kPa (1 bar)

VALVE CHARACTERISTICS

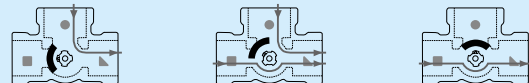
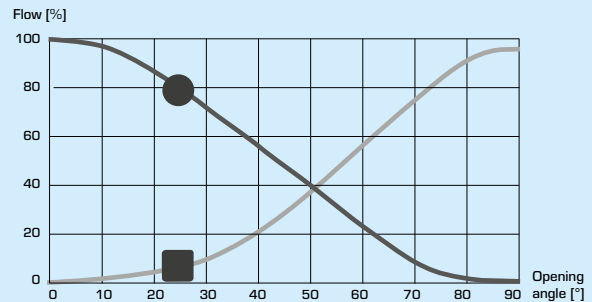

The integrated actuator:

Actuator type: _____ ARA661 Quick fit
 Control signal: _____ 3-point
 Power supply: _____ 230 ± 10% V AC, 50 Hz
 Power consumption: _____ 5 VA
 Running time 90°: _____ 120s
 Enclosure rating: _____ IP41
 Protection class: _____ II

ACTUATOR WIRING*

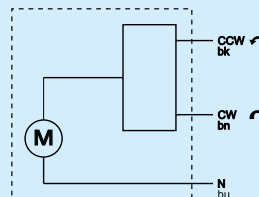

The integrated circulation pump:

Type: _____ Wilo RSTG 15/7.5
 Power supply: _____ 230 ± 10% V AC, 50/60 Hz
 Cable length: _____ 3m
 Power consumption: _____ 4-75 W
 Enclosure rating: _____ IP X4D
 Insulation class: _____ F
 EEI (Energy Efficiency Index): _____ <0,21

PUMP WIRING*

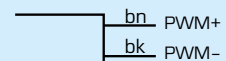
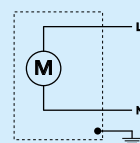

Pumpspeed could be controlled by PWM signal

* The actuator and circulation pump should be preceded by a multi-pole contact breaker in the fixed installation.

CIRCULATION UNIT

MIXING FUNCTION, SERIES GRA300

DIMENSIONING, PUMP CAPACITY DIAGRAM

Example: Start with the heating demand of heating circuit (e.g. 25 kW) and move horizontally to the right in the diagram to the $\Delta t = 15^\circ\text{C}$ (temperature difference between flow and return of the heating circuit). Next go up and find working flow point and read the available pressure of the pump on the left - $\Delta p = 62 \text{ kPa}$.

SERIES GRA300 –available pressure

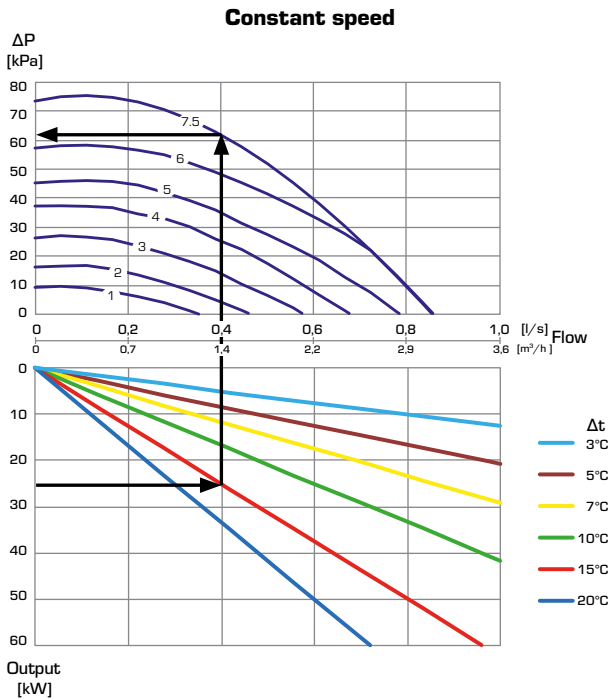

SERIES GRA300 –available pressure

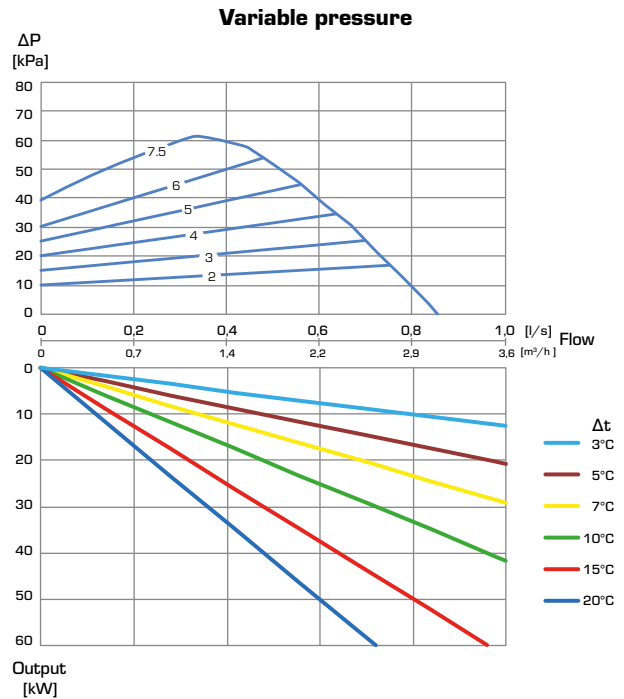

INSTALLATION EXAMPLES

